

INDEX

1J (JIC MALE 74° CONESEAT)	5
1J4(45° JIC MALE 74° CONE).....	6
1J9(90° JIC MALE 74° CONE).....	7
1JF(JIC MALE 74° CONE/ORFS MALE).....	8
1JN(JIC MALE 74° CONE/NPT MALE).....	9
1JN4(45° JIC MALE 74° CONE/NPT MALE).....	11
1JN9(90° JIC MALE 74° CONE/NPT MALE).....	12
1JN9-L(90° JIC MALE 74° CONE/LONG NPT MALE).....	14
1JN9-LL(90° JIC MALE 74° CONE/LONGER NPT MALE).....	15
1JO(JIC MALE 74° CONE/SAE O-RING BOSS).....	16
1JO4-OG(45° JIC MALE 74° CONE/SAE O-RING BOSS).....	18
1JO9-OG(90° JIC MALE 74° CONE/SAE O-RING BOSS).....	19
1JO-L(LONG JIC MALE 74° CONE/SAE MALE O-RNG BOSS).....	20
1JO9-L(90° LONG JIC MALE 74° CONE/SAE MALE O-RNG BOSS).....	21
1N(NPT MALE).....	22
1N9(90° NPT MALE).....	23
1NO(NPT MALE/SAE O-RING BOSS).....	24
1NO9-OG(90° NPT MALE/SAE O-RING BOSS).....	25
1O(SAE O-RING BOSS).....	26
1O-OG(SAE O-RING BOSS).....	27

1F(ORFS MALE).....	28
1F9(90° ORFS MALE).....	29
1FN(ORFS MALE/NPT MALE).....	30
1FN4(45° ORFS MALE/NPT MALE).....	31
1FN9(90° ORFS MALE/NPT MALE).....	32
1FO(ORFS MALE/SAE O-RING BOSS).....	33
1FO4-OG(45° ORFS MALE/SAE O-RING BOSS).....	35
1FO9-OG(90° ORFS MALE/SAE O-RING BOSS).....	36
2J(JIC MALE 74° CONE/JIC FEMALE 74° SEAT).....	37
2J4(45°JIC MALE 74°CONE/JIC FEMALE 74° SEAT).....	39
2J9(90°JIC MALE 74°CONE/JIC FEMALE 74° SEAT).....	40
2JF(JIC MALE 74° CONE/ORFS FEMALE).....	41
2NF(NPT MALE/ORFS FEMALE).....	42
2NJ(NPT MALE/JIC FEMALE 74° SEAT).....	43
2NJ9(90°NPT MALE/JIC FEMALE 74° SEAT).....	44
2OF(SAE O-RING BOSS/ORFS FEMALE).....	45
2OF9-OG(90° SAE O-RING BOSS/ORFS FEMALE).....	45
2OG(SAE O-RING BOSS/JIC FEMALE 74°SEAT).....	46
2OG9-OG(90°SAE O-RING BOSS/JIC FEMALE 74°SEAT).....	47
2F(ORFS MALE/ORFS FEMALE).....	48
2F4(45° ORFS MALE/ORFS FEMALE).....	49
2F9(90° ORFS MALE/ORFS FEMALE).....	50

2FJ(ORFS MALE/ORFS FEMALE).....	50
3F(ORFS FEMALE FLAT).....	51
3J(JIC FEMALE 74° SEAT).....	52
3J4(45° JIC FEMALE 74°SEAT).....	53
3J9(90° JIC FEMALE 74°SEAT).....	53
4F(ORFS MALE PLUG).....	54
4J(JIC MALE 74° CONE PLUG).....	55
4N(NPT MALE PLUG).....	56
4NN(NPT MALE HOLLOW HEX PLUG).....	57
4O(SAE O-RING BOSS PLUG).....	58
4ON(SAE O-RING BOSS HOLLOW HEX PLUG).....	59
4P(SAE MALE 90° CONE PLUG).....	59
5J(JIC MALE 74° CONE/JIC FEMALE 74° SEAT).....	60
5JN(JIC MALE 74° CONE/NPT FEMALE).....	61
5JN-L(JIC MALE 74° CONE/NPT FEMALE).....	62
5JN9(90° JIC MALE 74° CONE/NPT FEMALE).....	63
5J-S(JIC MALE/JIC FEMALE).....	64
5N(NPT MALE/NPT FEMALE).....	65
5N4(45° NPT MALE/NPT FEMALE).....	67
5N9(90° NPT MALE/NPT FEMALE).....	68
5NO(NPT MALE/SAE FEMALE).....	69
5O(SAE O-RING BOSS/SAE FEMALE).....	70

50N(SAE O-RING BOSS/NPT FEMALE).....	71
50N9-OG(90° SAE O-RING BOSS/NPT FEMALE).....	73
6F(ORFS MALE BULKHEAD).....	74
7N(NPT FEMALE).....	75
7N4(45° NPT FEMALE).....	76
7N9(90° NPT FEMALE).....	77
7NJ9-S(90° NPT FEMALE/JIC FEMALE 74°).....	78
7NJ-S(NPT FEMALE/JIC FEMALE 74° SEAT).....	79
9J(JIC FEMALE 74° SEAT PLUG).....	80
9N(NPT FEMALE PLUG).....	81
AJ(JIC MALE 74° CONE).....	82
AN(NPT MALE).....	83
JN(NPT FEMALE/NPT MALE/NPT FEMALE).....	84
KN(NPT MALE/NPT FEMALE/NPT MALE).....	84
HN(NPT FEMALE/NPT FEMALE/NPT MALE).....	85
NB200(JIC TRIPLE LOCK NUT).....	86
NB200-F(ORFS NUT).....	87
NB300(JIC INCH SLEEVE).....	88
NB300-F(ORFS INCH SLEEVE).....	89
NB500(JIC METRIC SLEEVE).....	90
NB500-F(ORFS METRIC SLEEVE).....	91
NOTE.....	92

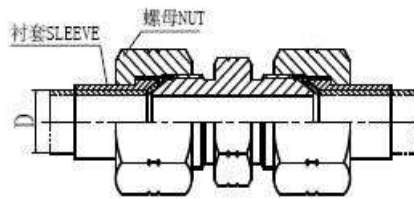
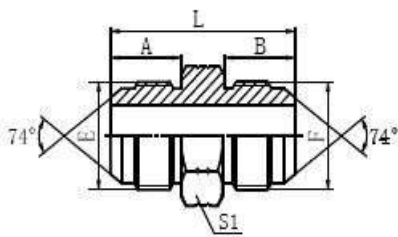

美制 JIC 外螺纹 74°外锥

JIC MALE 74° CONE SEAT

代号 P/N	螺纹 Thread		尺寸 DIMENSIONS			
	E	F	A	B	L	S1
1J-04	7/16"X20	7/16"X20	14	14	34	12
1J-04-05	7/16"X20	1/2"X20	14	14	34	14
1J-04-06	7/16"X20	9/16"X18	14	14.1	34.1	17
1J-04-08	7/16"X20	3/4"X16	14	16.7	38.5	22
1J-05	1/2"X20	1/2"X20	14	14	34	14
1J-05-06	1/2"X20	9/16"X18	14	14.1	34	17
1J-05-08	1/2"X20	3/4"X16	14	16.7	38.5	22
1J-05-10	1/2"X20	7/8"X14	14	19.3	41	24
1J-06	9/16"X18	9/16"X18	14.4	14.1	34.2	17
1J-06-08	9/16"X18	3/4"X16	14.1	16.7	38.5	22
1J-06-10	9/16"X18	7/8"X14	14.1	19.3	41.5	24
1J-06-12	9/16"X18	1.1/16"X12	14.1	21.9	46	30
1J-08-06	3/4"X16	9/16"X18	16.7	14.1	38.8	22
1J-08	3/4"X16	3/4"X16	16.7	16.7	42	22
1J-08-10	3/4"X16	7/8"X14	16.7	19.3	44	24
1J-08-12	3/4"X16	1.1/16"X12	16.7	21.9	48.5	30
1J-08-16	3/4"X16	1.5/16"X12	16.7	23.1	51	36
1J-10	7/8"X14	7/8"X14	19.3	19.3	46.5	24
1J-10-12	7/8"X14	1.1/16"X12	19.3	21.9	51	30
1J-10-16	7/8"X14	1.5/16"X12	19.3	23.1	53.5	36
1J-12	1.1/16"X12	1.1/16"X12	21.9	21.9	54	30
1J-12-14	1.1/16"X12	1.3/16"X12	21.9	22.6	55.5	32
1J-12-16	1.1/16"X12	1.5/16"X12	21.9	23.1	56	36

1J-14	1.3/16"X12	1.3/16"X12	22.6	22.6	56	32
1J-14-16	1.3/16"X12	1.5/16"X12	22.6	23.1	56.5	36
1J-16	1.5/16"X12	1.5/16"X12	23.1	23.1	57	36
1J-16-20	1.5/16"X12	1.5/8"X12	23.1	24.3	60.5	46
1J-20	1.5/8"X12	1.5/8"X12	24.3	24.3	62	46
1J-20-24	1.5/8"X12	1.7/8"X12	24.3	27.5	67	50
1J-24	1.7/8"X12	1.7/8"X12	27.5	27.5	70	50
1J-32	2.1/2"X12	2.1/2"X12	33.9	33.9	85	65

Note: Nut and sleeve should be ordered separately. The nut NB200 and sleeve NB500 is suitable for metric tube, the nut NB200 and sleeve NB300 is suitable for inch tube.

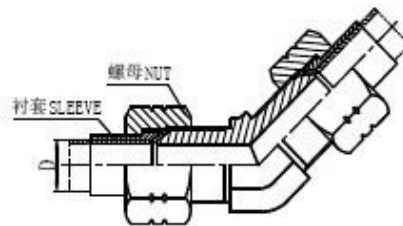
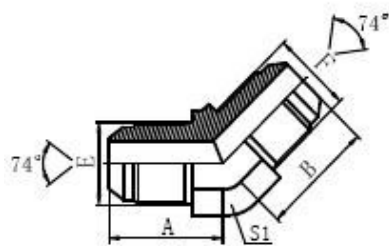

1J4

45°美制 JIC 外螺纹 74°外
锥

45° JIC MALE 74° CONE

代号 P/N	螺纹 Thread		尺寸 DIMENSIONS			
	E	F	A	B	S1	
1J4-04	7/16"X20	7/16"X20	21.5	21.5	11	
1J4-05	1/2"X20	1/2"X20	23	23	14	
1J4-06	9/16"X18	9/16"X18	22.8	22.8	14	
1J4-08	3/4"X16	3/4"X16	26.8	26.8	19	
1J4-10	7/8"X14	7/8"X14	31	31	22	
1J4-12	1.1/16"X12	1.1/16"X12	35.5	35.5	27	
1J4-16	1.5/16"X12	1.5/16"X12	38.5	38.5	33	

Note: Nut and sleeve should be ordered separately. The nut NB200 and sleeve NB500 is suitable for metric tube, the nut NB200 and sleeve NB300 is suitable for inch tube.

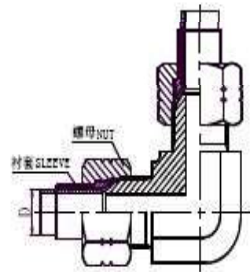
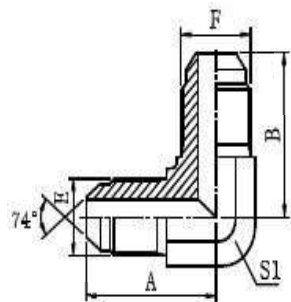

1J9

90°美制 JIC 外螺纹 74°外锥

90° JIC MALE 74° CONE

代号 P/N	螺纹 Thread		尺寸 DIMENSIONS			
	E	F	A	B	S1	
1J9-04	7/16"X20	7/16"X20	24.5	24.5	11	
1J9-05	1/2"X20	1/2"X20	26.6	26.6	14	
1J9-05-06	1/2"X20	9/16"X18	26.6	26.9	14	
1J9-06	9/16"X18	9/16"X18	26.9	26.9	14	
1J9-06-08	9/16"X18	3/4"X16	30	32	19	
1J9-06-10	9/16"X18	7/8"X14	32	37.8	22	
1J9-08	3/4"X16	3/4"X16	32	32	19	
1J9-08-10	3/4"X16	7/8"X14	34.8	37.8	22	
1J9-10	7/8"X14	7/8"X14	37.8	37.8	22	
1J9-10-12	7/8"X14	1.1/16"X12	41	44.2	27	
1J9-12	1.1/16"X12	1.1/16"X12	44.2	44.2	27	
1J9-14	1.3/16"X12	1.3/16"X12	47.5	47.5	30	
1J9-16	1.5/16"X12	1.5/16"X12	49	49	33	

1J9-20	1.5/8"X12	1.5/8"X12	55.5	55.5	41	
1J9-24	1.7/8"X12	1.7/8"X12	62.5	62.5	48	
1J9-32	2.1/2"X12	2.1/2"X12	78	78	63	

Note: Nut and sleeve should be ordered separately. The nut NB200 and sleeve NB500 is suitable for metric tube, the nut NB200 and sleeve NB300 is suitable for inch tube.

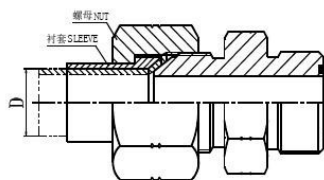
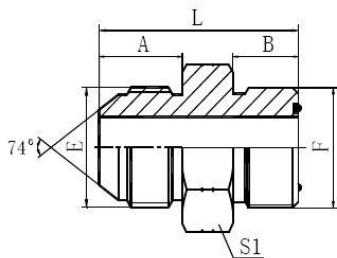

1JF

美制 JIC 外螺纹 74°外锥/ORFS 外螺纹

JIC MALE 74° CONE/ORFS MALE

代号 P/N	螺纹 Thread		O 形圈 O-RING		尺寸 DIMENSIONS			
	E	F		F END	A	B	L	S1
1JF-04	7/16" X 20	9/16" X 18		7.65X1.78	14	9.8	29.5	17
1JF-05-06	1/2" X 20	11/16" X 16		9.25X1.78	14	11.2	36	19
1JF-06	9/16" X 18	11/16" X 16		9.25X1.78	14.1	11.2	31	19
1JF-08	3/4" X 16	13/16" X 16		12.42X1.78	16.7	12.8	37.5	22
1JF-10	7/8" X 14	1" X 14		15.6X1.78	19.3	15.5	44.5	27
1JF-12	1.1/16 X 12	1.3/16" X		18.77X1.78	21.9	17	50	32
1JF-16	1.5/16" X	1.7/16" X		23.52X1.78	23.1	17.5	51.5	38
1JF-20	1.5/8" X 12	1.11/16" X		29.87X1.78	24.3	17.5	54.5	46
1JF-24	1.7/8" X 12	2" X 12		37.82X1.78	27.5	17.5	60	55

Note: Nut and sleeve should be ordered separately. The nut NB200 and sleeve NB500 is suitable for metric tube, the nut NB200 and sleeve NB300 is suitable for inch tube.

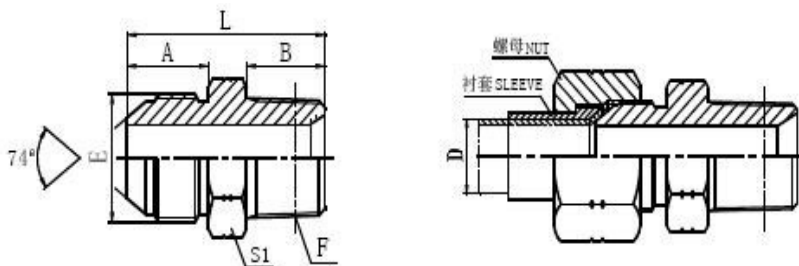

1JN

JIC 外螺纹 74°外锥/布锥管外螺纹

JIC MALE 74° CONE/NPT MALE

代号 P/N	螺纹 Thread		尺寸 DIMENSIONS			
	E	F	A	B	L	S1
1JN-04	7/16"X20	Z1/4"X18	14	15	35	17
1JN-04-02	7/16"X20	Z1/8"X27	14	10.5	30.5	12
1JN-04-06	7/16"X20	Z3/8"X18	14	16	36	19
1JN-04-08	7/16"X20	Z1/2"X14	14	19.5	41.5	24
1JN-05-02	1/2"X20	Z1/8"X27	14	10.5	30.5	14
1JN-05-04	1/2"X20	Z1/4"X18	14	15	35	17
1JN-05-06	1/2"X20	Z3/8"X18	14	16	36	19
1JN-05-08	1/2"X20	Z1/2"X14	14	19.5	41.5	24
1JN-06	9/16"X18	Z3/8"X18	14.1	16	36	19
1JN-06-02	9/16"X18	Z1/8"X27	14.1	10.5	30.5	17
1JN-06-04	9/16"X18	Z1/4"X18	14.1	15	34.5	17
1JN-06-08	9/16"X18	Z1/2"X14	14.1	19.5	41.5	24
1JN-06-12	9/16"X18	Z3/4"X14	15	19.5	44.5	30

1JN-08	3/4"X16	Z1/2"X14	16.7	19.5	44	24
1JN-08-04	3/4"X16	Z1/4"X18	16.7	15	39	22
1JN-08-06	3/4"X16	Z3/8"X18	16.7	16	40	22
1JN-08-12	3/4"X16	Z3/4"X14	16.7	19.5	46.5	30
1JN-08-16	3/4"X16	Z1"X11.5	16.7	25.5	53.5	36
1JN-10-06	7/8"X14	Z3/8"X18	19.3	16	43.5	24
1JN-10-08	7/8"X14	Z1/2"X14	19.3	19.5	47	24
1JN-10-12	7/8"X14	Z3/4"X14	19.3	19.5	49	30
1JN-12	1.1/16"X12	Z3/4"X14	21.9	19.5	51.5	30
1JN-12-06	1.1/16"X12	Z3/8"X18	21.9	16	48	30
1JN-12-08	1.1/16"X12	Z1/2"X14	21.9	19.5	51	30
1JN-12-16	1.1/16"X12	Z1"X11.5	21.9	25.5	58.5	36
1JN-12-20	1.1/16"X12	Z1.1/4"X11.5	21.9	26.5	61	46
1JN-14-12	1.3/16"X12	Z3/4"X14	22.6	19.5	53	32
1JN-16	1.5/16"X12	Z1"X11.5	23.1	25.5	58.5	36
1JN-16-06	1.5/16"X12	Z3/8"X18	23.1	17	51	36
1JN-16-08	1.5/16"X12	Z1/2"X14	23.1	19	54	36
1JN-16-12	1.5/16"X12	Z3/4"X14	23.1	19.5	53.5	36
1JN-16-20	1.5/16"X12	Z1.1/4"X11.5	23.1	26.5	62.5	46
1JN-20	1.5/8"X12	Z1.1/4"X11.5	24.3	26.5	63.5	46
1JN-20-12	1.5/8"X12	Z3/4"X14	24.3	20	57.5	46
1JN-20-16	1.5/8"X12	Z1"X11.5	24.3	25.5	63	46
1JN-20-24	1.5/8"X12	Z1.1/2"X11.5	24.3	27.5	67	50
1JN-24	1.7/8"X12	Z1.1/2"X11.5	27.5	27.5	70	50
1JN-24-16	1.7/8"X12	Z1"X11.5	27.5	25.5	68	50
1JN-24-20	1.7/8"X12	Z1.1/4"X11.5	27.5	26.5	69	50
1JN-24-32	1.7/8"X12	Z2"X11.5	27.5	27.5	72	65
1JN-32	2.1/2"X12	Z2"X11.5	33.9	27.5	78.5	65

1JN-32-20	2.1/2"X12	Z1.1/4"X11.5	33.9	26.5	77.5	65
1JN-32-24	2.1/2"X12	Z1.1/2"X11.5	33.9	27.5	78.5	65

Note: Nut and sleeve should be ordered separately. The nut NB200 and sleeve NB500 is suitable for metric tube, the nut NB200 and sleeve NB300 is suitable for inch tube.

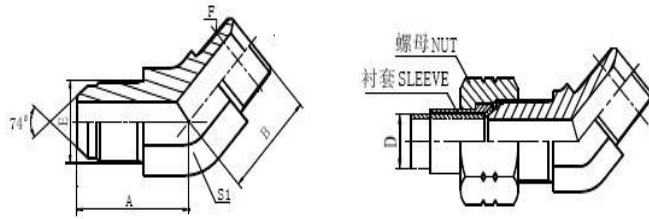

1JN4

45°JIC 外螺纹 74°外
锥/布锥管外螺纹

45°JIC MALE 74°
CONE/NPT MALE

代号 P/N	螺纹 Thread		尺寸 DIMENSIONS			
	E	F	A	B	S1	
1JN4-04-02	7/16"X20	Z1/8"X27	21.5	17	11	
1JN4-04	7/16"X20	Z1/4"X18	22.3	21	14	
1JN4-04-06	7/16"X20	Z3/8"X18	23	24	19	
1JN4-06-02	9/16"X18	Z1/8"X27	22.8	17.3	14	
1JN4-06-04	9/16"X18	Z1/4"X18	22.8	21	14	
1JN4-06	9/16"X18	Z3/8"X18	24	24	19	
1JN4-06-08	9/16"X18	Z1/2"X14	25	29.5	22	
1JN4-08-06	3/4"X16	Z3/8"X18	26.8	24	19	
1JN4-08	3/4"X16	Z1/2"X14	28	29.5	22	
1JN4-08-12	3/4"X16	Z3/4"X14	29	35	27	
1JN4-10-08	7/8"X14	Z1/2"X14	31	29.5	22	

1JN4-10-12	7/8"X14	Z3/4"X14	32	35	27	
1JN4-12-08	1.1/16"X12	Z1/2"X14	35.5	31	27	
1JN4-12	1.1/16"X12	Z3/4"X14	35.5	35	27	
1JN4-12-16	1.1/16"X12	Z1"X11.5	37.5	39	33	
1JN4-16-12	1.5/16"X12	Z3/4"X14	38.5	36.5	33	
1JN4-16	1.5/16"X12	Z1"X11.5	38.5	39	33	
1JN4-20	1.5/8"X12	Z1.1/4"X11.5	43	42	41	
1JN4-24	1.7/8"X12	Z1.1/2"X11.5	49	45	48	
1JN4-32	2.1/2"X12	Z2"X11.5	58	50	63	

Note: Nut and sleeve should be ordered separately. The nut NB200 and sleeve NB500 is suitable for metric tube, the nut NB200 and sleeve NB300 is suitable for inch tube.

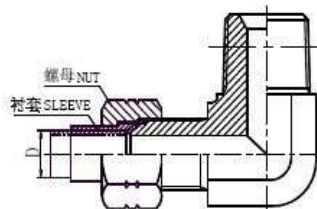
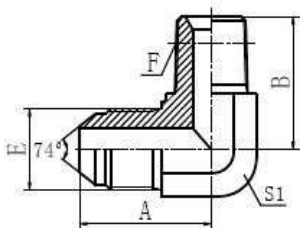

1JN9

90°JIC 外螺纹 74°外锥/布锥管外螺纹

90°JIC MALE 74° CONE/NPT MALE

代号 P/N	螺纹 Thread		尺寸 DIMENSIONS			
	E	F	A	B	S1	
1JN9-04	7/16"X20	Z1/4"X18	26.6	25.5	14	
1JN9-04-02	7/16"X20	Z1/8"X27	24.5	21	11	
1JN9-04-06	7/16"X20	Z3/8"X18	29.5	31	19	
1JN9-04-08	7/16"X20	Z1/2"X14	33.5	37.3	22	
1JN9-05-02	1/2"X20	Z1/8"X27	26.6	23.5	14	
1JN9-05-04	1/2"X20	Z1/4"X18	26.6	25.5	14	

1JN9-05-06	1/2"X20	Z3/8"X18	29.5	31	19	
1JN9-05-08	1/2"X20	Z1/2"X14	31.5	36.7	22	
1JN9-06	9/16"X18	Z3/8"X18	30	31	19	
1JN9-06-02	9/16"X18	Z1/8"X27	26.9	23.5	14	
1JN9-06-04	9/16"X18	Z1/4"X18	26.9	25.5	14	
1JN9-06-08	9/16"X18	Z1/2"X14	32	36.7	22	
1JN9-06-12	9/16"X18	Z3/4"X14	35.5	44	27	
1JN9-08	3/4"X16	Z1/2"X14	34.8	37.3	22	
1JN9-08-04	3/4"X16	Z1/4"X18	32	28.5	19	
1JN9-08-06	3/4"X16	Z3/8"X18	32	31	19	
1JN9-08-12	3/4"X16	Z3/4"X14	37.9	44	27	
1JN9-10-06	7/8"X14	Z3/8"X18	37.8	32.5	22	
1JN9-10-08	7/8"X14	Z1/2"X14	37.8	37.3	22	
1JN9-10-12	7/8"X14	Z3/4"X14	41	44	27	
1JN9-12	1.1/16"X12	Z3/4"X14	44.2	44	27	
1JN9-12-06	1.1/16"X12	Z3/8"X18	44.2	36.5	27	
1JN9-12-08	1.1/16"X12	Z1/2"X14	44.2	40	27	
1JN9-12-16	1.1/16"X12	Z1"X11.5	49	50	33	
1JN9-14-12	1.3/16"X12	Z3/4"X14	47.5	45	30	
1JN9-16	1.5/16"X12	Z1"X11.5	49	50	33	
1JN9-16-12	1.5/16"X12	Z3/4"X14	49	45.2	33	
1JN9-16-20	1.5/16"X12	Z1.1/4"X11.5	54	60.5	41	
1JN9-20	1.5/8"X12	Z1.1/4"X11.5	55.5	54.5	41	
1JN9-20-16	1.5/8"X12	Z1"X11.5	55.5	59.6	41	
1JN9-20-24	1.5/8"X12	Z1.1/2"X11.5	59.4	63	48	
1JN9-24	1.7/8"X12	Z1.1/2"X11.5	62.5	63	48	
1JN9-24-20	1.7/8"X12	Z1.1/4"X11.5	62.5	63	48	
1JN9-32	2.1/2"X12	Z2"X11.5	75.4	67.5	63	

Note: Nut and sleeve should be ordered separately. The nut NB200 and sleeve NB500 is suitable for metric tube, the nut NB200 and sleeve NB300 is suitable for inch tube.

1JN9-L

90°JIC 外螺纹 74°外锥/布锥管外螺
纹

90 ° JIC MALE 74 ° CONE/LONG

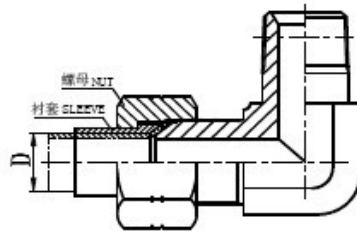
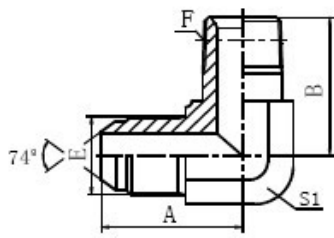

NPT MALE

代号 P/N	螺纹 Thread		尺寸 DIMENSIONS			
	E	F	A	B	S1	
1JN9-04L	7/16"X20	Z1/4"X18	26.6	40.1	14	
1JN9-04-02L	7/16"X20	Z1/8"X27	24.5	30	11	
1JN9-05-02L	1/2"X20	Z1/8"X27	26.6	31	14	
1JN9-05-04L	1/2"X20	Z1/4"X18	26.6	40.1	14	
1JN9-06-04L	9/16"X18	Z1/4"X18	26.9	40.1	14	
1JN9-06-08L	9/16"X18	Z1/2"X14	32	55.1	22	
1JN9-08-06L	3/4"X16	Z3/8"X18	32	46.2	19	
1JN9-08L	3/4"X16	Z1/2"X14	34.8	55.1	22	
1JN9-10-08L	7/8"X14	Z1/2"X14	37.8	55.1	22	
1JN9-12L	1.1/16"X12	Z3/4"X14	44.2	62	27	
1JN9-12-08L	1.1/16"X12	Z1/2"X14	44.2	60	27	
1JN9-14-12L	1.3/16"X12	Z3/4"X14	47.5	65.8	30	
1JN9-16-12L	1.5/16"X12	Z3/4"X14	49	65	33	
1JN9-16L	1.5/16"X12	Z1"X11.5	49	76.5	33	
1JN9-20L	1.5/8"X12	Z1.1/4"X11.5	55.5	93.7	41	

1JN9-24L	1.7/8"X12	Z1.1/2"X11.5	62.5	104.1	48	
1JN9-32L	2.1/2"X12	Z2"X11.5	78	122.2	63	

Note: Nut and sleeve should be ordered separately. The nut NB200 and sleeve NB500 is suitable for metric tube, the nut NB200 and sleeve NB300 is suitable for inch tube.

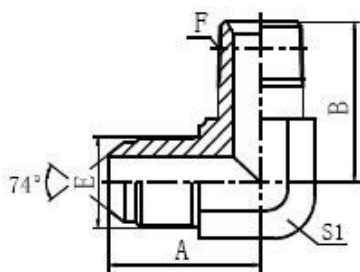

NPT MALE

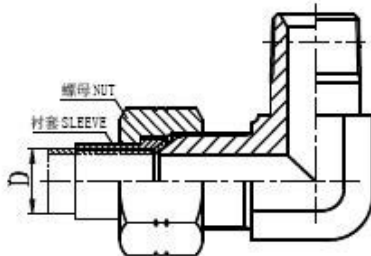

1JN9-LL

90°JIC 外螺纹 74°外锥/布锥管外螺纹

90°JIC MALE 74° CONE/LONGER

代号 P/N	螺纹 Thread		尺寸 DIMENSIONS			
	E	F	A	B	S1	
1JN9-04-02LL	7/16"X20	Z1/8"X27	24.5	39.6	11	
1JN9-05-02LL	1/2"X20	Z1/8"X27	26.6	41.4	14	
1JN9-06-04LL	9/16"X18	Z1/4"X18	26.9	52.6	14	
1JN9-08-06LL	3/4"X16	Z3/8"X18	32	61.5	19	
1JN9-10-08LL	7/8"X14	Z1/2"X14	37.8	72.9	22	
1JN9-12LL	1.1/16"X12	Z3/4"X14	44.2	83.3	27	
1JN9-14-12LL	1.3/16"X12	Z3/4"X14	47.5	91.9	30	
1JN9-16LL	1.5/16"X12	Z1"X11.5	49	102.9	33	
1JN9-20LL	1.5/8"X12	Z1.1/4"X11.5	55.5	127	41	

1JN9-24LL	1.7/8"X12	Z1.1/2"X11.5	62.5	141	48	
1JN9-32LL	2.1/2"X12	Z2"X11.5	78	168.4	63	

Note: Nut and sleeve should be ordered separately. The nut NB200 and sleeve NB500 is suitable for metric tube, the nut NB200 and sleeve NB300 is suitable for inch tube.

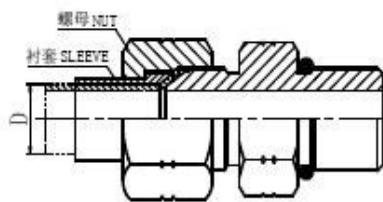
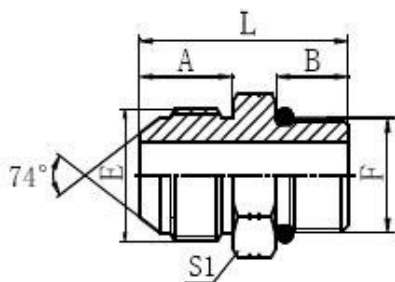

1JO

美制 JIC 外螺纹 74°外锥/SAE 外螺纹带

O 形

JIC MALE 74° CONE/SAE O-RING

BOSS

代号 P/N	螺纹 Thread		O 形圈 O-RING		尺寸 DIMENSIONS			
	E	F		F END	A	B	L	S1
1JO-04	7/16"X20	7/16"X20		8.92X1.83	14	9.14	29	14
1JO-04-06	7/16"X20	9/16"X18		11.89X1.98	14	9.93	30	17
1JO-04-08	7/16"X20	3/4"X16		16.36X2.21	14	11.13	33	22
1JO-05	1/2"X20	1/2"X20		10.52X1.83	14	9.14	29	17
1JO-05-04	1/2"X20	7/16"X20		8.92X1.83	14	9.14	29	14
1JO-05-06	1/2"X20	9/16"X18		11.89X1.98	14	9.93	30	17
1JO-06	9/16"X18	9/16"X18		11.89X1.98	14.1	9.93	30	17
1JO-06-04	9/16"X18	7/16"X20		8.92X1.83	14.1	9.14	29	17
1JO-06-08	9/16"X18	3/4"X16		16.36X2.21	14.1	11.13	33	22

1JO-06-10	9/16"X18	7/8"X14		19.18X2.46	14.1	12.7	37	27
1JO-06-12	9/16"X18	1.1/16"X12		23.47X2.95	14.1	15.09	40	32
1JO-08	3/4"X16	3/4"X16		16.36X2.21	16.7	11.13	36	22
1JO-08-06	3/4"X16	9/16"X18		11.89X1.98	16.7	9.93	35	22
1JO-08-10	3/4"X16	7/8"X14		19.18X2.46	16.7	12.7	40	27
1JO-08-12	3/4"X16	1.1/16"X12		23.47X2.95	16.7	15.09	43	32
1JO-08-14	3/4"X16	1.3/16"X12		26.62X2.95	16.7	15.09	43	36
1JO-10	7/8"X14	7/8"X14		19.18X2.46	19.3	12.7	42.5	27
1JO-10-06	7/8"X14	9/16"X18		11.89X1.98	19.3	9.93	37	24
1JO-10-08	7/8"X14	3/4"X16		16.36X2.21	19.3	11.13	39	24
1JO-10-12	7/8"X14	1.1/16"X12		23.47X2.95	19.3	15.09	45.5	32
1JO-10-14	7/8"X14	1.3/16"X12		26.62X2.95	19.3	15.09	45.5	36
1JO-10-16	7/8"X14	1.5/16"X12		29.74X2.95	19.3	15.09	45.5	38
1JO-12	1.1/16"X12	1.1/16"X12		23.47X2.95	21.9	15.09	48	32
1JO-12-06	1.1/16"X12	9/16"X18		11.89X1.98	21.9	9.93	41.8	30
1JO-12-08	1.1/16"X12	3/4"X16		16.36X2.21	21.9	11.13	43	30
1JO-12-10	1.1/16"X12	7/8"X14		19.18X2.46	21.9	12.7	45	30
1JO-12-14	1.1/16"X12	1.3/16"X12		26.62X2.95	21.9	15.09	48	36
1JO-12-16	1.1/16"X12	1.5/16"X12		29.74X2.95	21.9	15.09	48	38
1JO-12-20	1.1/16"X12	1.5/8"X12		37.46X3.00	21.9	15.09	52	50
1JO-14	1.3/16"X12	1.3/16"X12		26.62X2.95	22.6	15.09	48.5	36
1JO-14-12	1.3/16"X12	1.1/16"X12		23.47X2.95	22.6	15.09	48.5	32
1JO-14-16	1.3/16"X12	1.5/16"X12		29.74X2.95	22.6	15.09	50.5	38
1JO-16	1.5/16"X12	1.5/16"X12		29.74X2.95	23.1	15.09	49	38
1JO-16-10	1.5/16"X12	7/8"X14		19.18X2.46	23.1	12.7	46.5	36
1JO-16-12	1.5/16"X12	1.1/16"X12		23.47X2.95	23.1	15.09	49	36
1JO-16-20	1.5/16"X12	1.5/8"X12		37.46X3.00	23.1	15.09	53	50
1JO-20	1.5/8"X12	1.5/8"X12		37.46X3.00	24.3	15.09	54.5	50
1JO-20-14	1.5/8"X12	1.3/16"X12		26.62X2.95	24.3	15.09	52.5	46

1JO-20-16	1.5/8"X12	1.5/16"X12		29.74X2.95	24.3	15.09	52.5	46
1JO-20-24	1.5/8"X12	1.7/8"X12		43.69X3.00	24.3	15.09	54.5	55
1JO-24	1.7/8"X12	1.7/8"X12		43.69X3.00	27.5	15.09	57.5	55
1JO-24-16	1.7/8"X12	1.5/16"X12		29.74X2.95	27.5	15.09	57.5	50
1JO-24-20	1.7/8"X12	1.5/8"X12		37.46X3.00	27.5	15.09	57.5	50
1JO-24-32	1.7/8"X12	2.1/2"X12		59.36X3.00	27.5	15.09	59.5	70
1JO-32	2.1/2"X12	2.1/2"X12		59.36X3.00	33.9	15.09	66	70

Note: Nut and sleeve should be ordered separately. The nut NB200 and sleeve NB500 is suitable for metric tube, the nut NB200 and sleeve NB300 is suitable for inch tube.

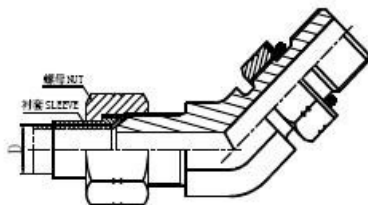
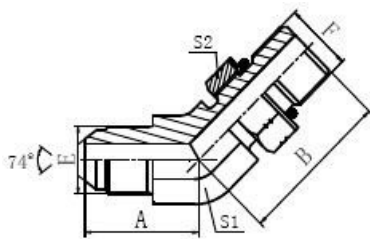

1JO4-OG

45°美制 JIC 外螺纹 74°外锥/SAE 外螺纹带 O

45°JIC MALE 74°CONE/SAE O-RING

BOSS

代号 P/N	螺纹 Thread		O 形圈 O-RING		尺寸 DIMENSIONS			
	E	F		F END	A	B	S1	S2
1JO4-04OG	7/16"X2	7/16"X2		8.92X1.8	21	24	11	17
1JO4-04-06O	7/16"X2	9/16"X1		11.89X1.9	22.3	27.5	14	19
1JO4-05OG	1/2"X20	1/2"X2		10.52X1.8	22	26.7	14	17
1JO4-06OG	9/16"X1	9/16"X1		11.89X1.9	23.5	28	14	19
1JO4-06-04O	9/16"X1	7/16"X2		8.92X1.8	22.8	26	14	17
1JO4-06-08O	9/16"X1	3/4"X1		16.36X2.2	25	32.5	19	24
1JO4-08OG	3/4"X16	3/4"X1		16.36X2.2	25.8	32.5	19	24
1JO4-08-06O	3/4"X16	9/16"X1		11.89X1.9	25.8	30	19	19

1JO4-08-120	3/4"X16	1.1/16"X		23.47X2.9	30	43.9	27	32
1JO4-100G	7/8"X14	7/8"X1		19.18X2.4	29.5	38.7	22	27
1JO4-10-080	7/8"X14	3/4"X1		16.36X2.2	29.5	33	22	27
1JO4-10-120	7/8"X14	1.1/16"X		23.47X2.9	33	43.9	27	32
1JO4-120G	1.1/16"X1	1.1/16"X		23.47X2.9	34	43.5	27	32
1JO4-12-100	1.1/16"X1	7/8"X1		19.18X2.4	34	42	27	27
1JO4-12-160	1.1/16"X1	1.5/16"X		29.74X2.9	37	45.5	33	41
1JO4-160G	1.5/16"X1	1.5/16"X		29.74X2.9	38	45.5	33	41
1JO4-16-120	1.5/16"X1	1.1/16"X		23.47X2.9	38	45	33	32
1JO4-16-200	1.5/16"X1	1.5/8"X1		37.46X3.0	40.5	47	41	50
1JO4-200G	1.5/8"X1	1.5/8"X1		37.46X3.0	42	48.5	41	50
1JO4-240G	1.7/8"X1	1.7/8"X1		43.69X3.0	48	50	48	55

Note: Nut and sleeve should be ordered separately. The nut NB200 and sleeve NB500 is suitable for metric tube, the nut NB200 and sleeve NB300 is suitable for inch tube.

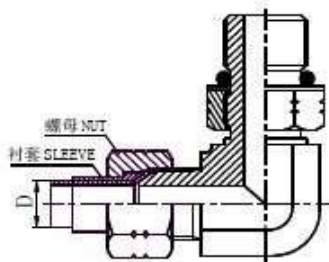
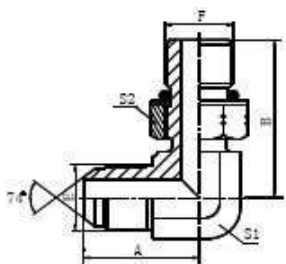

1JO9-OG

90°美制 JIC 外螺纹 74°外锥/SAE 外螺纹带 O 形

90°JIC MALE 74°CONE/SAE O-RING BOSS

代号 P/N	螺纹 Thread		O 形圈 O-RING		尺寸 DIMENSIONS			
	E	F		F END	A	B	S1	S2
1JO9-040G	7/16"X20	7/16"X20		8.92X1.83	24.5	27.2	11	17

1JO9-05-04OG	1/2"X20	7/16"X20		8.92X1.83	26.6	30	14	17
1JO9-05OG	1/2"X20	1/2"X20		10.52X1.83	26.6	30	14	17
1JO9-06OG	9/16"X18	9/16"X18		11.89X1.98	26.9	31.8	14	19
1JO9-06-08OG	9/16"X18	3/4"X16		16.36X2.21	30	36.8	19	24
1JO9-08-06OG	3/4"X16	9/16"X18		11.89X1.98	33	33.5	19	19
1JO9-08OG	3/4"X16	3/4"X16		16.36X2.21	33	36.8	19	24
1JO9-10OG	7/8"X14	7/8"X14		19.18X2.46	37.8	44	22	27
1JO9-12-10OG	1.1/16"X1	7/8"X14		19.18X2.46	44.2	47	27	27
1JO9-12OG	1.1/16"X1	1.1/16"X12		23.47X2.95	44.2	51	27	32
1JO9-12-16OG	1.1/16"X1	1.5/16"X12		29.74X2.95	48	54.5	33	41
1JO9-14OG	1.3/16"X1	1.3/16"X12		26.62X2.95	47.5	53	30	36
1JO9-16-14OG	1.5/16"X1	1.3/16"X12		26.62X2.95	49	56	33	36
1JO9-16OG	1.5/16"X1	1.5/16"X12		29.74X2.95	49	54.5	33	41
1JO9-16-20OG	1.5/16"X1	1.5/8"X12		37.46X3.00	54	59	41	50
1JO9-20-16OG	1.5/8"X12	1.5/16"X12		29.74X2.95	55.5	59.5	41	41
1JO9-20OG	1.5/8"X12	1.5/8"X12		37.46X3.00	55.5	59	41	50
1JO9-20-24OG	1.5/8" X12	1.7/8"X12		43.69X3.00	59.4	63	48	55
1JO9-24OG	1.7/8"X12	1.7/8"X12		43.69X3.00	62.5	63	48	55

Note: Nut and sleeve should be ordered separately. The nut NB200 and sleeve NB500 is suitable for metric tube, the nut NB200 and sleeve NB300 is suitable for inch tube.

1JO-L

加长 JIC 外螺纹 74°外锥/SAE 外螺纹带 O 形圈

圈

LONG JIC MALE 74° CONE/SAE MALE

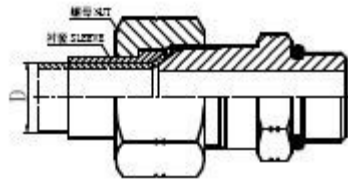
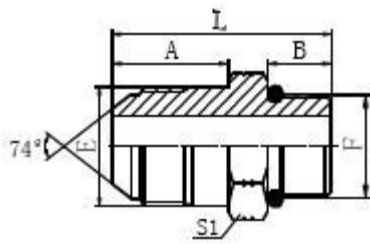

O-RNG BOSS

代号 P/N	螺纹 Thread		O 形圈 O-RING		尺寸 DIMENSIONS			
	E	F		F END	A	B	L	S1
1JO-04L	7/16"X20	7/16"X20		8.92X1.83	35	9.1	50.5	14
1JO-05L	1/2"X20	1/2"X20		10.52X1.83	37	9.1	52.5	17
1JO-06-08L	9/16"X18	3/4"X16		16.36X2.21	39	11.1	58	22
1JO-06L	9/16"X18	9/16"X18		11.89X1.98	39	9.9	55	17
1JO-08-10L	3/4"X16	7/8"X14		19.18X2.46	48	12.7	71	27
1JO-08L	3/4"X16	3/4"X16		16.36X2.21	48	11.1	67.5	22
1JO-10-08L	7/8"X14	3/4"X16		16.36X2.21	53	11.1	42	24
1JO-10-12L	7/8"X14	1.1/16"X12		23.47X2.95	53	15.1	79	32
1JO-10L	7/8"X14	7/8"X14		19.18X2.46	53	12.7	76	27
1JO-12-10L	1.1/16"X12	7/8"X14		19.18X2.46	63	12.7	85.5	32
1JO-12-16L	1.1/16"X12	1.5/16"X12		29.74X2.95	63	15.1	91	38
1JO-12L	1.1/16"X12	1.1/16"X12		23.47X2.95	63	15.1	89	32
1JO-16-12L	1.5/16"X12	1.1/16"X12		23.47X2.95	72	15.1	100	38
1JO-16L	1.5/16"X12	1.5/16"X12		29.74X2.95	72	15.1	100	38
1JO-20L	1.5/8"X12	1.5/8"X12		37.46X3.00	88.1	15.1	118	50

Note: Nut and sleeve should be ordered separately. The nut NB200 and sleeve NB500 is suitable for metric tube, the nut NB200 and sleeve NB300 is suitable for inch tube.

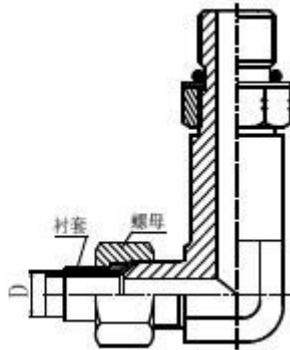
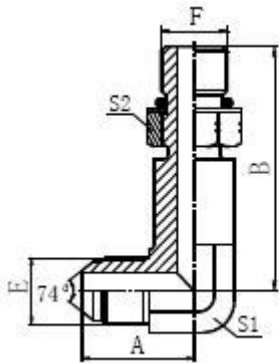

1JO9-L

90°加长 JIC 外螺纹 74°外锥/SAE 外螺纹带 O 形圈

90 ° LONG JIC MALE 74 ° CONE/SAE MALE O-

RNG BOSS

代号 P/N	螺纹 Thread		O 形圈 O-RING		尺寸 DIMENSIONS			
	E	F		F END	A	B	S1	S2
1JO9-04OG/L	7/16"X20	7/16"X20		8.92X1.83	24.5	44	11	17
1JO9-06OG/L	9/16"X18	9/16"X18		11.89X1.98	26.9	52.8	14	19
1JO9-08OG/L	3/4"X16	3/4"X16		16.36X2.21	33	63.5	19	24
1JO9-10OG/L	7/8"X14	7/8"X14		19.18X2.46	37.8	73.4	22	27
1JO9-12OG/L	1.1/16"X12	1.1/16"X12		23.47X2.95	44.2	84.8	27	32
1JO9-16OG/L	1.5/16"X12	1.5/16"X12		29.74X2.95	48.8	94.5	33	41

Note: Nut and sleeve should be ordered separately. The nut NB200 and sleeve NB500 is suitable for metric tube, the nut NB200 and sleeve NB300 is suitable for inch tube.

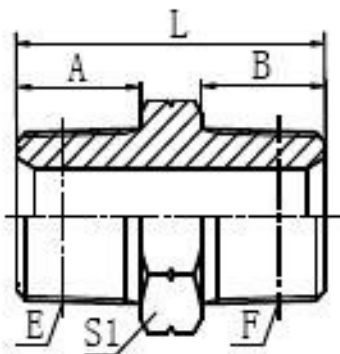

1N 美制布锥管外螺纹

NPT MALE

代号 P/N	螺纹 Thread		尺寸 DIMENSIONS			
	E	F	A	B	L	S1
1N-02	Z1/8"X27	Z1/8"X27	10.5	10.5	27	12
1N-02-04	Z1/8"X27	Z1/4"X18	10.5	15	31	17
1N-02-06	Z1/8"X27	Z3/8"X18	10.5	16	32	19
1N-04	Z1/4"X18	Z1/4"X18	15	15	36	17
1N-04-06	Z1/4"X18	Z3/8"X18	15	16	37	19
1N-04-08	Z1/4"X18	Z1/2"X14	15	19.5	41.5	22
1N-04-12	Z1/4"X18	Z3/4"X14	15	19.5	43.5	30
1N-06	Z3/8"X18	Z3/8"X18	16	16	38	19
1N-06-08	Z3/8"X18	Z1/2"X14	16	19.5	43.5	22
1N-06-12	Z3/8"X18	Z3/4"X14	16	19.5	45.5	30
1N-08	Z1/2"X14	Z1/2"X14	19.5	19.5	47	22
1N-08-12	Z1/2"X14	Z3/4"X14	19.5	19.5	49	30
1N-08-16	Z1/2"X14	Z1"X11.5	19.5	25.5	56	36
1N-12	Z3/4"X14	Z3/4"X14	19.5	19.5	49	30
1N-12-16	Z3/4"X14	Z1"X11.5	19.5	25.5	55	36
1N-12-20	Z3/4"X14	Z1.1/4"X11.5	19.5	26.5	59	46
1N-16	Z1"X11.5	Z1"X11.5	25.5	25.5	62	36
1N-16-20	Z1"X11.5	Z1.1/4"X11.5	25.5	26.5	64	46
1N-16-24	Z1"X11.5	Z1.1/2"X11.5	25.5	27.5	68	50

1N-20	Z1.1/4"X11.5	Z1.1/4"X11.5	26.5	26.5	66	46
1N-20-24	Z1.1/4"X11.5	Z1.1/2"X11.5	26.5	27.5	69	50
1N-24	Z1.1/4"X11.5	Z1.1/2"X11.5	27.5	27.5	70	50
1N-24-32	Z1.1/2"X11.5	Z2"X11.5	27.5	27.5	72	65
1N-32	Z2"X11.5	Z2"X11.5	27.5	27.5	72	65

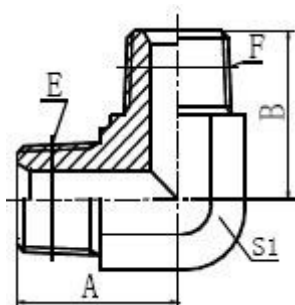

1N9

90° 美制布锥管外螺纹

90° NPT MALE

代号 P/N	螺纹 Thread		尺寸 DIMENSIONS			
	E	F	A	B	S1	
1N9-02	Z1/8"X27	Z1/8"X27	21	21	11	
1N9-04	Z1/4"X18	Z1/4"X18	25.5	25.5	14	
1N9-04-06	Z1/4"X18	Z3/8"X18	28	31	19	
1N9-06	Z3/8"X18	Z3/8"X18	31	31	19	
1N9-06-08	Z3/8"X18	Z1/2"X14	33.8	37.3	22	
1N9-08	Z1/2"X14	Z1/2"X14	37.3	37.3	22	
1N9-08-12	Z1/2"X14	Z3/4"X14	40	44	27	
1N9-12	Z3/4"X14	Z3/4"X14	44	44	27	
1N9-16	Z1"X11.5	Z1"X11.5	50	50	33	
1N9-20	Z1.1/4"X11.5	Z1.1/4"X11.5	53	53	41	

1N9-24	Z1.1/2"X11.5	Z1.1/2"X11.5	63	63	48	
1N9-32	Z2"X11.5	Z2"X11.5	68	68	63	

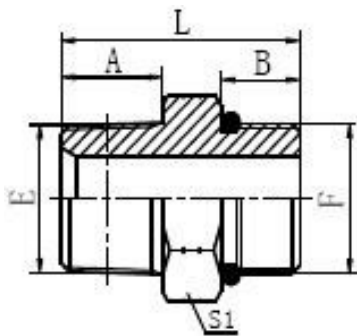

1NO

美制 NPT 外螺纹/SAE 外螺纹带 O 形圈

NPT MALE/SAE O-RING BOSS

代号 P/N	螺纹 Thread		O 形圈 O-RING		尺寸 DIMENSIONS			
	E	F		F END	A	B	L	S1
1NO-02-04	Z1/8"X27	7/16"X20		8.92X1.83	10.5	9.1	25.5	14
1NO-04	Z1/4"X18	7/16"X20		8.92X1.83	15	9.1	30	14
1NO-04-06	Z1/4"X18	9/16"X18		11.89X1.98	15	9.9	31	17
1NO-06	Z3/8"X18	9/16"X18		11.89X1.98	16	9.9	32	19
1NO-06-08	Z3/8"X18	3/4"X16		16.36X2.21	16	11.1	35	22
1NO-08	Z1/2"X14	3/4"X16		16.36X2.21	19.5	11.1	38.5	22
1NO-08-10	Z1/2"X14	7/8"X14		19.18X2.46	19.5	12.7	42	27
1NO-08-12	Z1/2"X14	1.1/16"X12		23.47X2.95	19.5	15.09	45.5	32
1NO-12	Z3/4"X14	1.1/16"X12		23.47X2.95	19.5	15.1	45.5	32
1NO-16	Z1"X11.5	1.5/16"X12		29.74X2.95	25.5	15.1	51.5	38
1NO-20	1.1/4"X11.5	1.5/8"X12		37.46X3.00	26.5	15.1	56.5	50

1NO-24	1.1/2"X11.5	1.7/8"X12		43.69X3.00	27.5	15.1	57.5	55
--------	-------------	-----------	--	------------	------	------	------	----

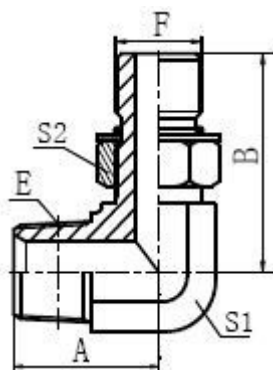

1NO9-OG

90° 美制 NPT 外螺纹/SAE 外螺纹带 O 形圈

90° NPT MALE/SAE O-RING BOSS

代号 P/N	螺纹 Thread		O 形圈 O-RING		尺寸 DIMENSIONS			
	E	F	E END	F END	A	B	S1	S2
1NO9-02-04O	Z1/8"X27	7/16"X20		8.92X1.83	22	27.2	11	17
1NO9-02-05O	Z1/8"X27	1/2"X20		10.52X1.83	23.5	29.9	14	17
1NO9-04-06O	Z1/4"X18	9/16"X18		11.89X1.98	25.5	31.8	14	19
1NO9-06-08O	Z3/8"X18	3/4"X16		16.36X2.21	30	36.8	19	24
1NO9-08-10O	Z1/2"X14	7/8"X14		19.18X2.46	36	44	22	27
1NO9-12OG	Z3/4"X14	1.1/16"X1		23.47X2.95	43	51	27	32
1NO9-12-14O	Z3/4"X14	1.3/16"X1		26.62X2.95	45	53	30	36
1NO9-16OG	Z1"X11.5	1.5/16"X1		29.74X2.95	49	54.5	33	41
1NO9-20OG	Z1.1/4X11.	1.5/8"X12		37.46X3.00	53	59	41	50

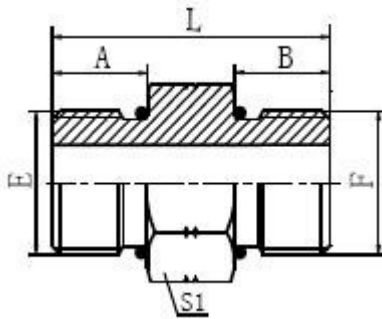

10

SAE 外螺纹带 O 形圈

SAE O-RING BOSS

代号 P/N	螺纹 Thread		O 形圈 O-RING		尺寸 DIMENSIONS			
	E	F	E END	F END	A	B	L	S1
10-04	7/16"X20	7/16"X20	8.92X1.83	8.92X1.83	9.14	9.14	24.5	14
10-05	1/2"X20	1/2"X20	10.52X1.8	10.52X1.83	9.14	9.14	24.5	17
10-06	9/16"X18	9/16"X18	11.89X1.9	11.89X1.98	9.93	9.93	26	17
10-08	3/4"X16	3/4"X16	16.36X2.2	16.36X2.21	11.13	11.13	30.5	22
10-10	7/8"X14	7/8"X14	19.18X2.4	19.18X2.46	12.7	12.7	35.5	27
10-12	1.1/16"X12	1.1/16"X12	23.47X2.9	23.47X2.95	15.09	15.09	41	32
10-16	1.5/16"X12	1.5/16"X12	29.74X2.9	29.74X2.95	15.09	15.09	41	38

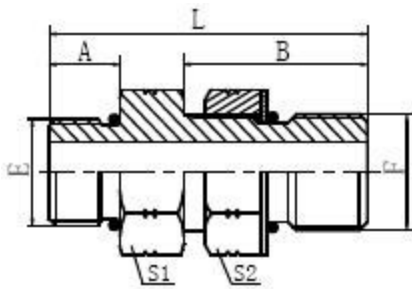

10-OG

SAE 外螺纹带 O 形圈

SAE O-RING BOSS

代号 P/N	螺纹 Thread		O 形圈 O-RING		尺寸 DIMENSIONS				
	E	F	E END	F END	A	B	L	S1	S2
10-04OG	7/16"X20	7/16"X20	8.92X1.83	8.92X1.83	9.14	18	31	14	17
O-04-06OG	7/16"X20	9/16"X18	8.92X1.83	11.89X1.9	9.14	20	35.1	17	19
10-06OG	9/16"X18	9/16"X18	11.89X1.9	11.89X1.9	9.93	20	36	17	19
O-06-08OG	9/16"X18	3/4"X16	11.89X1.9	16.36X2.2	9.93	22	40	22	24
10-08OG	3/4"X16	3/4"X16	16.36X2.2	16.36X2.2	11.13	22	40	22	24
O-08-12OG	3/4"X16	1.1/16"X12	16.36X2.2	23.47X2.9	11.13	29	51	32	32
10-10OG	7/8"X14	7/8"X14	19.18X2.4	19.18X2.4	12.7	26	46	27	27
10-12OG	1.1/16"X12	1.1/16"X12	23.47X2.9	23.47X2.9	15.1	29	54	32	32
10-16OG	1.5/16"X12	1.5/16"X12	29.74X2.9	29.74X2.9	15.1	29	54	38	41
10-20OG	1.5/8"X12	1.5/8"X12	37.46X3.0	37.46X3.0	15.1	29	54	50	50
10-24OG	1.7/8"X12	1.7/8"X12	43.69X3.0	43.69X3.0	15.1	29	54	55	55

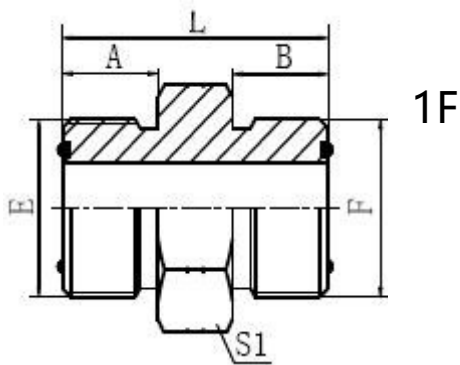

美制 ORFS 外螺纹

ORFS MALE

代号 P/N	螺纹 Thread		O 形圈 O-RING		尺寸 DIMENSIONS				
	E	F	E END	F END	A	B	L	S1	S2
1F-04	9/16"X18	9/16"X18	7.65X1.78	7.65X1.78	9.8	9.8	27.5	17	
1F-04-06	9/16"X18	11/16"X16	7.65X1.78	9.25X1.78	9.8	11.2	29.7	19	
1F-04-08	9/16"X18	13/16"X16	7.65X1.78	12.42X1.78	9.8	12.8	32.5	22	
1F-04-10	9/16"X18	1"X14	7.65X1.78	15.6X1.78	9.8	15.5	37	27	
1F-04-12	9/16"X18	1.3/16"X12	7.65X1.78	18.77X1.78	9.8	17	40	32	
1F-06	11/16"X16	11/16"X16	9.25X1.78	9.25X1.78	11.2	11.2	31.1	19	
1F-06-08	11/16"X16	13/16"X16	9.25X1.78	12.42X1.78	11.2	12.8	33.8	22	
1F-06-10	11/16"X16	1"X14	9.25X1.78	15.6X1.78	11.2	15.5	38.5	27	
1F-06-12	11/16"X16	1.3/16"X12	9.25X1.78	18.77X1.78	11.2	17	41.3	32	
1F-08	13/16"X16	13/16"X16	12.42X1.78	12.42X1.78	12.8	12.8	35.4	22	
1F-08-10	13/16"X16	1"X14	12.42X1.78	15.6X1.78	12.8	15.5	40	27	
1F-08-12	13/16"X16	1.3/16"X12	12.42X1.78	18.77X1.78	12.8	17	43	32	
1F-08-16	13/16"X16	1.7/16"X12	12.42X1.78	23.52X1.78	12.8	17.5	44.5	38	
1F-10	1"X14	1"X14	15.6X1.78	15.6X1.78	15.5	15.5	42.5	27	
1F-10-12	1"X14	1.3/16"X12	15.6X1.78	18.77X1.78	15.5	17	45.5	32	
1F-12	1.3/16"X12	1.3/16"X12	18.77X1.78	18.77X1.78	17	17	47.1	32	
1F-12-16	1.3/16"X12	1.7/16"X12	18.77X1.78	23.52X1.78	17	17.5	45.5	38	
1F-12-20	1.3/16"X12	1.11/16"X12	18.77X1.78	29.87X1.78	17	17.5	50.8	46	
1F-12-24	1.3/16"X12	2"X12	18.77X1.78	37.82X1.78	17	17.5	52.5	55	
1F-16	1.7/16"X12	1.7/16"X12	23.52X1.78	23.52X1.78	17.5	17.5	49.3	38	

1F-16-20	1.7/16"X12	1.11/16"X12	23.52X1.78	29.87X1.78	17.5	17.5	51.3	46	
1F-16-24	1.7/16"X12	2"X12	23.52X1.78	37.82X1.78	17.5	17.5	53	55	
1F-20	1.11/16"X1	1.11/16"X12	29.87X1.78	29.87X1.78	17.5	17.5	51.3	46	
1F-20-24	1.11/16"X1	2"X12	29.87X1.78	37.82X1.78	17.5	17.5	53	55	
1F-24	2"X12	2"X12	37.82X1.78	37.82X1.78	17.5	17.5	53	55	

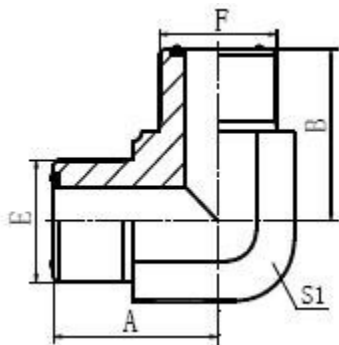

1F9

90° 美制 ORFS 外螺纹

90° ORFS MALE

代号 P/N	螺纹 Thread		O 形圈 O-RING		尺寸 DIMENSIONS				
	E	F	E END	F END	A	B	S1		
1F9-04	9/16X18	9/16X18	7.65X1.78	7.65X1.78	23	23	14		
1F9-04-06	9/16X18	11/16"X16	7.65X1.78	9.25X1.78	25.5	27	19		
1F9-04-08	9/16X18	13/16"X16	7.65X1.78	12.42X1.78	28	31	22		
1F9-06	11/16"X16	11/16"X16	9.25X1.78	9.25X1.78	27.5	27.5	19		
1F9-06-08	11/16"X16	13/16"X16	9.25X1.78	12.42X1.78	29	31	22		
1F9-08	13/16"X16	13/16"X16	12.42X1.78	12.42X1.78	31	31	22		
1F9-08	13/16"X16	1.3/16"X12	12.42X1.78	18.77X1.78	35.5	40.3	30		
1F9-10	1"X14	1"X14	15.6X1.78	15.6X1.78	36.5	36.5	27		
1F9-12	1.3/16"X12	1.3/16"X12	18.77X1.78	18.77X1.78	41	41	30		

1F9-16	1.7/16"X12	1.7/16"X12	23.52X1.78	23.52X1.78	44.5	44.5	36		
1F9-20	1.11/16"X12	1.11/16"X12	29.87X1.78	29.87X1.78	47.5	47.5	41		

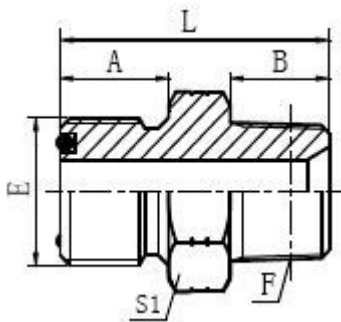

1FN 美制 ORFS 外螺纹/布锥管外螺

纹

ORFS MALE/NPT MALE

代号 P/N	螺纹 Thread		O 形圈 O-RING	尺寸 DIMENSIONS				
	E	F		A	B	L	S1	
1FN-04	9/16"X18	Z1/4"X18	7.65X1.78	9.8	15	30.5	17	
1FN-04-02	9/16"X18	Z1/8"X27	7.65X1.78	9.8	10.5	26.5	17	
1FN-04-06	9/16"X18	Z3/8"X18	7.65X1.78	9.8	16	30.5	19	
1FN-06	11/16"X16	Z3/8"X18	9.25X1.78	11.2	16	33.5	19	
1FN-06-04	11/16"X16	Z1/4"X18	9.25X1.78	11.2	15	32	19	
1FN-06-08	11/16"X16	Z1/2"X14	9.25X1.78	11.2	19.5	39	24	
1FN-08	13/16"X16	Z1/2"X14	12.42X1.78	12.8	19.5	40	24	
1FN-08-06	13/16"X16	Z3/8"X18	12.42X1.78	12.8	16	36.5	22	
1FN-08-12	13/16"X16	Z3/4"X14	12.42X1.78	12.8	19.5	42.5	30	
1FN-10-08	1"X14	Z1/2"X14	15.6X1.78	15.5	19.5	45	27	

1FN-10-12	1"X14	Z3/4"X14	15.6X1.78	15.5	19.5	45	30	
1FN-12	1.3/16"X12	Z3/4"X14	18.77X1.78	17	19.5	47	32	
1FN-12-08	1.3/16"X12	Z1/2"X14	18.77X1.78	17	19.5	46.5	32	
1FN-12-16	1.3/16"X12	Z1"X11.5	18.77X1.78	17	25.5	53.5	36	
1FN-16	1.7/16"X12	Z1"X11.5	23.52X1.78	17.5	25.5	53.5	38	
1FN-16-12	1.7/16"X12	Z3/4"X14	23.52X1.78	17.5	19.5	48	38	
1FN-20-16	1.11/16"X12	Z1"X11.5	23.52X1.78	17.5	25.5	55.5	46	
1FN-20	1.11/16"X12	Z1.1/4"X11.5	29.87X1.78	17.5	26.5	56.5	46	
1FN-24	2"X12	Z1.1/2"X11.5	37.82X1.78	17.5	27.5	59.5	55	

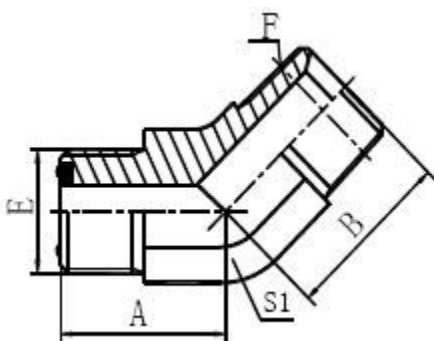

1FN4

45° 美制 ORFS 外螺纹/布锥管外螺纹

45° ORFS MALE/NPT MALE

代号 P/N	螺纹 Thread		O 形圈 O-RING	尺寸 DIMENSIONS			
	E	F		A	B	S1	
1FN4-04-02	9/16"X18	Z1/8"X27	7.65X1.78	18.3	18	14	
1FN4-04	9/16"X18	Z1/4"X18	7.65X1.78	18.3	21	14	
1FN4-04-06	9/16"X18	Z3/8"X18	7.65X1.78	19.5	25	19	
1FN4-06-04	11/16"X16	Z1/4"X18	9.25X1.78	20.5	22	19	
1FN4-06	11/16"X16	Z3/8"X18	9.25X1.78	20.5	25	19	

1FN4-06-08	11/16"X16	Z1/2"X14	9.25X1.78	22	29.5	22		
1FN4-08-06	13/16"X16	Z3/8"X18	12.42X1.78	24	26	22		
1FN4-08	13/16"X16	Z1/2"X14	12.42X1.78	24	29.5	22		
1FN4-10-08	1"X14	Z1/2"X14	15.6X1.78	28	31	27		
1FN4-12	1.3/16"X12	Z3/4"X14	18.77X1.78	30.7	35.5	30		
1FN4-16	1.7/16"X12	Z1"X11.5	23.52X1.78	33	40	36		
1FN4-20	1.11/16"X12	Z1.1/4"X11.5	29.87X1.78	36	42.5	41		

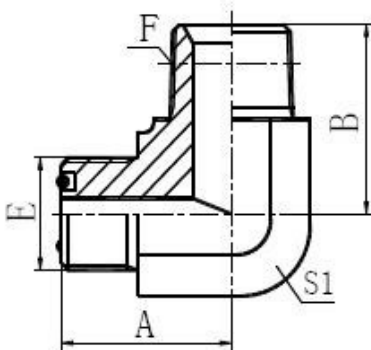

1FN9

90°美制 ORFS 外螺纹/布锥管外螺纹

90° ORFS MALE/NPT MALE

代号 P/N	螺纹 Thread		O形圈 O-RING	尺寸 DIMENSIONS				
	E	F		A	B	S1		
1FN9-04	9/16X18	Z1/4"X18	7.65X1.78	23	25.5	14		

1FN9-04-02	9/16X18	Z1/8"X27	7.65X1.78	23	24	14		
1FN9-06	11/16"X16	Z3/8"X18	9.25X1.78	27.5	31	19		
1FN9-06-04	11/16"X16	Z1/4"X18	9.25X1.78	27	28.5	19		
1FN9-06-08	11/16"X16	Z1/2"X14	9.25X1.78	29	36.7	22		
1FN9-08	13/16"X16	Z1/2"X14	12.42X1.78	31	37.3	22		
1FN9-08-06	13/16"X16	Z3/8"X18	12.42X1.78	31	33.5	22		
1FN9-08-12	13/16"X16	Z3/4"X14	12.42X1.78	34.5	44	27		
1FN9-10-08	1"X14	Z1/2"X14	15.6X1.78	36.5	40	27		
1FN9-10-12	1"X14	Z3/4"X14	15.6X1.78	36.5	44	27		
1FN9-12	1.3/16"X12	Z3/4"X14	18.77X1.78	41	45.5	30		
1FN9-12-08	1.3/16"X12	Z1/2"X14	18.77X1.78	41	41.2	30		
1FN9-12-16	1.3/16"X12	Z1"X11.5	18.77X1.78	43	50	33		
1FN9-16	1.7/16"X12	Z1"X11.5	23.52X1.78	44.5	51.5	36		
1FN9-16-12	1.7/16"X12	Z3/4"X14	23.52X1.78	44.5	49	36		
1FN9-20	1.11/16"X12	Z1.1/4"X11.5	29.87X1.78	47.5	54.5	41		
1FN9-20-16	1.11/16"X12	Z1"X11.5	29.87X1.78	47.5	54	41		

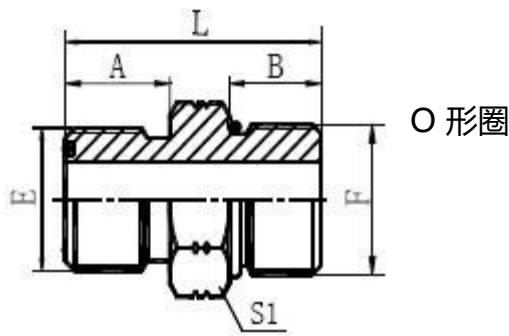

1FO 美制 ORFS 外螺纹/SAE 带

ORFS MALE/SAE O-RING BOSS

代号 P/N	螺纹 Thread		O 形圈 O-RING		尺寸 DIMENSION ;			
	E	F	E END	F END	A	B	L	S1
1FO-04	9/16"X18	7/16"X20	7.65X1.78	8.92X1.83	9.8	11	28.7	17
1FO-04-05	9/16"X18	1/2"X20	7.65X1.78	10.52X1.83	9.8	11	28.7	17
1FO-04-06	9/16"X18	9/16"X18	7.65X1.78	11.89X1.98	9.8	12	29.5	17
1FO-04-08	9/16"X18	3/4"X16	7.65X1.78	16.36X2.21	9.8	14	33.5	22
1FO-06	11/16"X16	9/16"X18	9.25X1.78	11.89X1.98	11.2	12	31.9	19
1FO-06-04	11/16"X16	7/16"X20	9.25X1.78	8.92X1.83	11.2	11	31	19
1FO-06-05	11/16"X16	1/2"X20	9.25X1.78	10.52X1.83	11.2	11	30.9	19
1FO-06-08	11/16"X16	3/4"X16	9.25X1.78	16.36X2.21	11.2	14	35	22
1FO-06-10	11/16"X16	7/8"X14	9.25X1.78	19.18X2.46	11.2	16	38.5	27
1FO-08	13/16"X16	3/4"X16	12.42X1.78	16.36X2.21	12.8	14	36.6	22
1FO-08-06	13/16"X16	9/16"X18	12.42X1.78	11.89X1.98	12.8	12	34.5	22
1FO-08-10	13/16"X16	7/8"X14	12.42X1.78	19.18X2.46	12.8	16	40.5	27
1FO-08-12	13/16"X16	1.1/16"X12	12.42X1.78	23.47X2.95	12.8	18.5	44.5	32
1FO-08-16	13/16"X16	1.5/16"X12	12.42X1.78	29.74X2.95	12.8	18.5	44.5	38
1FO-10	1"X14	7/8"X14	15.6X1.78	19.18X2.46	15.5	16	43.1	27
1FO-10-08	1"X14	3/4"X16	15.6X1.78	16.36X2.21	15.5	14	41	27
1FO-10-12	1"X14	1.1/16"X12	15.6X1.78	23.47X2.95	15.5	18.5	47	32
1FO-10-14	1"X14	1.3/16"X12	15.6X1.78	26.62X2.95	15.5	18.5	47	36
1FO-10-16	1"X14	1.5/16"X12	15.6X1.78	29.74X2.95	15.5	18.5	48.3	38

1FO-12	1.3/16"X12	1.1/16"X12	18.77X1.78	23.47X2.95	17	18.5	48.6	32
1FO-12-08	1.3/16"X12	3/4"X16	18.77X1.78	16.36X2.21	17	14	44	32
1FO-12-10	1.3/16"X12	7/8"X14	18.77X1.78	19.18X2.46	17	16	46	32
1FO-12-16	1.3/16"X12	1.5/16"X12	18.77X1.78	29.74X2.95	17	18.5	49.8	38
1FO-16	1.7/16"X12	1.5/16"X12	23.52X1.78	29.74X2.95	17.5	18.5	50.3	38
1FO-16-12	1.7/16"X12	1.1/16"X12	23.52X1.78	23.47X2.95	17.5	18.5	50	38
1FO-16-14	1.7/16"X12	1.3/16"X12	23.52X1.78	26.62X2.95	17.5	18.5	50	38
1FO-16-20	1.7/16"X12	1.5/8"X12	23.52X1.78	37.46X3.00	17.5	18.5	52	50
1FO-20	1.11/16"X12	1.5/8"X12	29.87X1.78	37.46X3.00	17.5	18.5	52.3	50
1FO-20-16	1.11/16"X12	1.5/16"X12	29.87X1.78	29.74X2.95	17.5	18.5	52	46
1FO-20-24	1.11/16"X12	1.7/8"X12	29.87X1.78	43.69X3.00	17.5	18.5	52	55
1FO-24	2"X12	1.7/8"X12	37.82X1.78	43.69X3.00	17.5	18.5	54.1	55
1FO-24-20	2"X12	1.5/8"X12	37.82X1.78	37.46X3.00	17.5	18.5	54.1	55

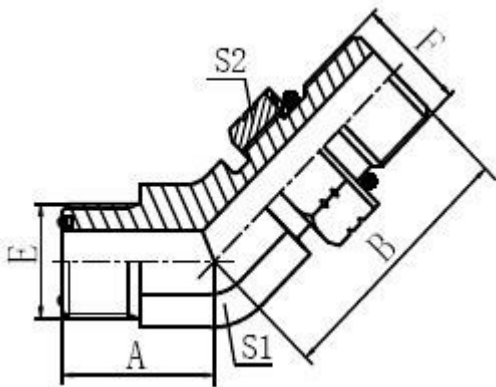

1FO4-OG

45°美制 ORFS 外螺纹/SAE 带 O 形圈

45° ORFS MALE/SAE O-RING BOSS

代号 P/N	螺纹 Thread		O 形圈 O-RING		尺寸 DIMENSIONS				
	E	F	E END	F END	A	B	S1	S2	
1FO4-04OG	9/16"X18	7/16"X20	7.65X1.78	8.92X1.83	18.3	26	14	17	
1FO4-04-06	9/16"X18	9/16"X18	7.65X1.78	11.89X1.98	18.3	28	14	19	
1FO4-06-04	11/16"X16	7/16"X20	9.25X1.78	8.92X1.83	20.5	27.3	19	17	
1FO4-06-08	11/16"X16	3/4"X16	9.25X1.78	16.36X2.21	20.5	32.5	19	24	
1FO4-06OG	11/16"X16	9/16"X18	9.25X1.78	11.89X1.98	20.5	29.5	19	19	
1FO4-08-06	13/16"X16	9/16"X18	12.42X1.78	11.89X1.98	24	30.8	22	19	
1FO4-08OG	13/16"X16	3/4"X16	12.42X1.78	16.36X2.21	24	34	22	24	
1FO4-08-10	13/16"X16	7/8"X14	12.42X1.78	19.18X2.46	24	39.5	22	27	
1FO4-08-12	13/16"X16	1.1/16"X1	12.42X1.78	23.47X2.95	25.5	44	27	32	
1FO4-10-08	1"X14	3/4"X16	15.6X1.78	16.36X2.21	28	34	27	24	
1FO4-10OG	1"X14	7/8"X14	15.6X1.78	19.18X2.46	28	41.5	27	27	
1FO4-10-12	1"X14	1.1/16"X1	15.6X1.78	23.47X2.95	28	44	27	32	
1FO4-12OG	1.3/16"X12	1.1/16"X1	18.77X1.78	23.47X2.95	31.5	46	33	32	
1FO4-12-16	1.3/16"X12	1.5/16"X1	18.77X1.78	29.74X2.95	32.5	47.9	36	41	
1FO4-16-12	1.7/16"X12	1.1/16"X1	23.52X1.78	23.47X2.95	33	47.9	36	32	

1FO4-16OG	1.7/16"X12	1.5/16"X1	23.52X1.78	29.74X2.95	33	47.9	36	41	
1FO4-20-24	1.11/16"X12	1.7/8"X12	29.87X1.78	43.69X3.00	38	51.5	48	55	
1FO4-20OG	1.11/16"X12	1.5/8"X12	29.87X1.78	37.46X3.00	35.5	48.8	41	50	
1FO4-24OG	2"X12	1.7/8"X12	37.82X1.78	43.69X3.00	39	53.5	50	55	

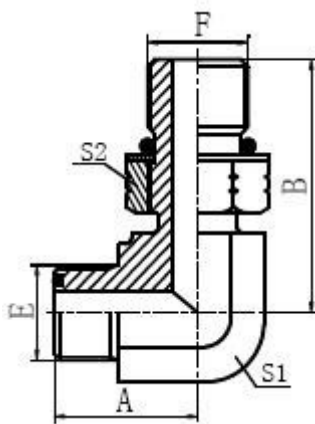

1FO9-OG

45°美制 ORFS 外螺纹/SAE 带 O 形圈

45° ORFS MALE/SAE O-RING BOSS

代号 P/N	螺纹 Thread		O 形圈 O-RING		尺寸 DIMENSIONS				
	E	F	E END	F END	A	B	S1	S2	
1FO9-04OG	9/16"X18	7/16"X20	7.65X1.78	8.92X1.83	23	30.3	14	17	
1FO9-04-06	9/16"X18	9/16"X18	7.65X1.78	11.89X1.9	23	32	14	19	
1FO9-04-08	9/16"X18	3/4"X16	7.65X1.78	16.36X2.2	25.5	38	19	24	
1FO9-06OG	11/16"X16	9/16"X18	9.25X1.78	11.89X1.9	27.5	34.5	19	19	
1FO9-06-04	11/16"X16	7/16"X20	9.25X1.78	8.92X1.83	27.5	33.5	19	17	
1FO9-06-08	11/16"X16	3/4"X16	9.25X1.78	16.36X2.2	27.5	38	19	24	
1FO9-06-10	11/16"X16	7/8"X14	9.25X1.78	19.18X2.4	29	44	22	27	
1FO9-06-12	11/16"X16	1.1/16"X12	9.25X1.78	23.47X2.9	32	51	27	32	
1FO9-08OG	13/16"X16	3/4"X16	12.42X1.78	16.36X2.2	31	40.5	22	24	
1FO9-08-06	13/16"X16	9/16"X18	12.42X1.78	11.89X1.9	31	37	22	19	
1FO9-08-10	13/16"X16	7/8"X14	12.42X1.78	19.18X2.4	31	45.3	22	27	
1FO9-08-12	13/16"X16	1.1/16"X12	12.42X1.78	23.47X2.9	34.5	52	27	32	

1FO9-100G	1"X14	7/8"X14	15.6X1.78	19.18X2.4	36.5	50.8	27	27	
1FO9-10-06	1"X14	9/16"X18	15.6X1.78	11.89X1.9	36.5	41	27	19	
1FO9-10-08	1"X14	3/4"X16	15.6X1.78	16.36X2.2	36.5	45	27	24	
1FO9-10-12	1"X14	1.1/16"X12	15.6X1.78	23.47X2.9	36.5	52	27	32	
1FO9-120G	1.3/16"X12	1.1/16"X12	18.77X1.78	23.47X2.9	41	54	30	32	
1FO9-12-08	1.3/16"X12	3/4"X16	18.77X1.78	16.36X2.2	40.3	45	30	24	
1FO9-12-10	1.3/16"X12	7/8"X14	18.77X1.78	19.18X2.4	41	52.8	30	27	
1FO9-12-16	1.3/16"X12	1.5/16"X12	18.77X1.78	29.74X2.9	43	55.5	33	41	
1FO9-160G	1.7/16"X12	1.5/16"X12	23.52X1.78	29.74X2.9	48	60	41	41	
1FO9-16-12	1.7/16"X12	1.1/16"X12	23.52X1.78	23.47X2.9	48	60	41	32	
1FO9-200G	1.11/16"X12	1.5/8"X12	29.87X1.78	37.46X3.0	47.5	60.5	41	50	
1FO9-20-24	1.11/16"X12	1.7/8"X12	29.87X1.78	43.69X3.0	51.5	66.5	48	55	
1FO9-24-20	2"X12	1.5/8"X12	37.82X1.78	37.46X3.0	53.5	67.5	50	50	
1FO9-240G	2"X12	1.7/8"X12	37.82X1.78	43.69X3.0	53.5	67.5	50	55	

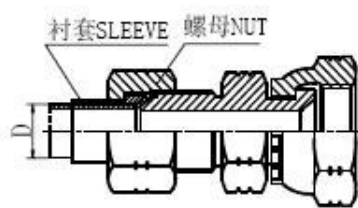
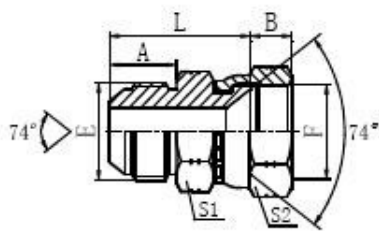

2J

JIC 外螺纹 74°外锥/JIC 内螺纹 74°内锥

JIC MALE 74° CONE/JIC FEMALE 74°

SEAT

代号 P/N	螺纹 Thread		O形圈 O-RING		尺寸 DIMENSIONS				
	E	F	E END	F END	A	B	L	S1	S2
2J-04	7/16"X20	7/16"X20			14	9	28	12	15
2J-04-05	7/16"X20	7/16"X20			14	9.5	28.5	12	17
2J-04-06	7/16"X20	9/16"X18			14	10.5	28.5	14	19

2J-04-08	7/16"X20	3/4"X16			14	11	30.5	19	24
2J-05	1/2"X20	1/2"X20			14	9.5	29	14	17
2J-05-06	1/2"X20	9/16"X18			14	10.5	28.5	14	19
2J-05-08	1/2"X20	3/4"X16			14	11	30.5	19	24
2J-05-10	1/2"X20	7/8"X14			14	13	33	22	27
2J-06	9/16"X18	9/16"X18			14.1	10.5	29	17	19
2J-06-08	9/16"X18	3/4"X16			14.1	11	31	19	24
2J-06-10	9/16"X18	7/8"X14			14.1	13	33.5	22	27
2J-06-12	9/16"X18	1.1/16"X12			14.1	15	36.5	27	32
2J-08	3/4"X16	3/4"X16			16.7	11	36	22	24
2J-08-06	3/4"X16	9/16"X18			16.7	10.5	34	22	19
2J-08-10	3/4"X16	7/8"X14			16.7	13	36.5	22	27
2J-08-12	3/4"X16	1.1/16"X12			16.7	15	39.5	27	32
2J-10	7/8"X14	7/8"X14			19.3	13	39	24	27
2J-10-06	7/8"X14	9/16"X18			19.3	10.5	36	24	19
2J-10-08	7/8"X14	3/4"X16			19.3	11	38	24	24
2J-10-12	7/8"X14	1.1/16"X12			19.3	15	42	27	32
2J-12	1.1/16"X12	1.1/16"X12			21.9	15	44.5	30	32
2J-12-08	1.1/16"X12	3/4"X16			21.9	11	42.5	30	24
2J-12-10	1.1/16"X12	7/8"X14			21.9	13	43.5	30	27
2J-12-16	1.1/16"X12	1.5/16"X12			21.9	16	45.5	36	41
2J-12-20	1.1/16"X12	1.5/8"X12			21.9	17	49	41	50
2J-16	1.5/16"X12	1.5/16"X12			23.1	16	46.5	36	41
2J-16-20	1.5/16"X12	1.5/8"X12			23.1	17	50	41	50
2J-20	1.5/8"X12	1.5/8"X12			24.3	17	51.5	46	50
2J-20-24	1.5/8"X12	1.7/8"X12			24.3	20	52	46	55
2J-24	1.7/8"X12	1.7/8"X12			27.5	20	57	50	55
2J-24-32	1.7/8"X12	2.1/2"X12			27.5	24.5	59.5	65	75
2J-32	2.1/2"X12	2.1/2"X12			33.9	24.5	66	65	75

Note: Nut and sleeve should be ordered separately. The nut NB200 and sleeve NB500 is suitable for metric tube, the nut NB200 and sleeve NB300 is suitable for inch tube.

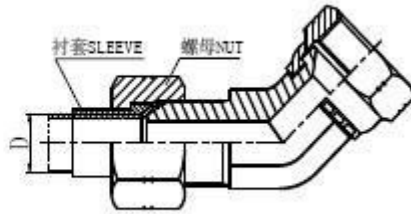
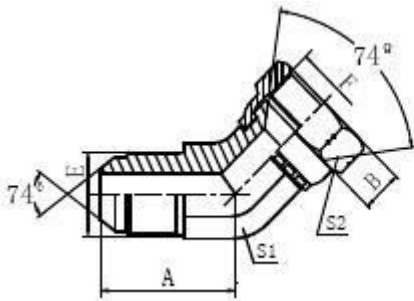

2J4

45° JIC 外螺纹 74°外锥/JIC 内螺纹 74°内锥

45°JIC MALE 74°CONE/JIC FEMALE 74°

SEAT

代号 P/N	螺纹 Thread		O 形圈 O-RING		尺寸 DIMENSIONS				
	E	F	E END	F END	A	B	S1	S2	
2J4-04	7/16"X20	7/16"X20			21.5	9	11	15	
2J4-05	1/2"X20	1/2"X20			22	9.5	14	17	
2J4-06	9/16"X18	9/16"X18			22.8	10.5	14	19	
2J4-08	3/4"X16	3/4"X16			26.8	11	19	24	
2J4-10	7/8"X14	7/8"X14			31	13	22	27	
2J4-12	1.1/16"X12	1.1/16"X12			35.5	15	27	32	
2J4-14	1.3/16"X12	1.3/16"X12			37	15	30	36	
2J4-16	1.5/16"X12	1.5/16"X12			38.5	16	33	41	
2J4-20	1.5/8"X12	1.5/8"X12			43	17	41	50	

2J4-24	1.7/8"X12	1.7/8"X12			49	20	48	55	
2J4-32	2.1/2"X12	2.1/2"X12			56	24.5	63	75	

Note: Nut and sleeve should be ordered separately. The nut NB200 and sleeve NB500 is suitable for metric tube, the nut NB200 and sleeve NB300 is suitable for inch tube.

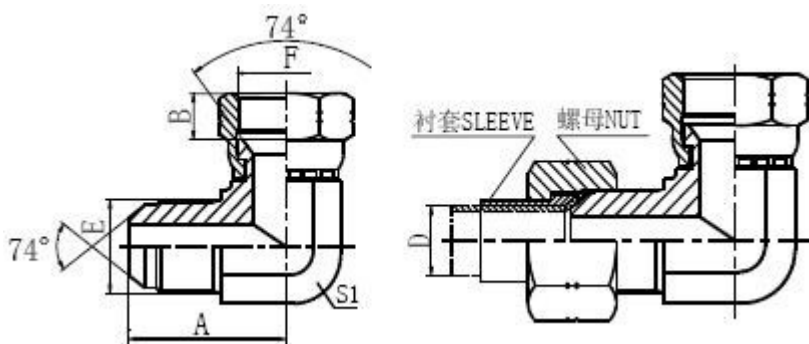

2J9

90° JIC 外螺纹 74°外锥/JIC 内螺纹 74°内锥

90° JIC MALE 74° CONE / JIC FEMALE 74°

SEAT

代号 P/N	螺纹 Thread		O形圈 O-RING		尺寸 DIMENSIONS				
	E	F	E END	F END	A	B	S1	S2	
2J9-04	7/16"X20	7/16"X20			24.5	9	11	15	
2J9-05	1/2"X20	1/2"X20			26.5	9.5	14	17	
2J9-06	9/16"X18	9/16"X18			26.9	10.5	14	19	
2J9-06-08	9/16"X18	3/4"X16			31.3	11	16	24	
2J9-08	3/4"X16	3/4"X16			33	11	19	24	
2J9-10	7/8"X14	7/8"X14			37.8	13	22	27	
2J9-10-08	7/8"X14	3/4"X16			37.8	11	22	24	
2J9-10-12	7/8"X14	1.1/16"X12			39.5	15	24	32	
2J9-12	1.1/16"X12	1.1/16"X12			44.2	15	27	32	

2J9-12-10	1.1/16"X12	7/8"X14			44.2	13	27	27	
2J9-14	1.3/16"X12	1.3/16"X12			47.5	15	30	36	
2J9-16	1.5/16"X12	1.5/16"X12			48.8	16	33	41	
2J9-20	1.5/8"X12	1.5/8"X12			55.5	17	41	50	
2J9-24	1.7/8"X12	1.7/8"X12			62.5	20	48	55	
2J9-32	2.1/2"X12	2.1/2"X12			75.4	24.5	63	75	

Note: Nut and sleeve should be ordered separately. The nut NB200 and sleeve NB500 is suitable for metric tube, the nut NB200 and sleeve NB300 is suitable for inch tube.

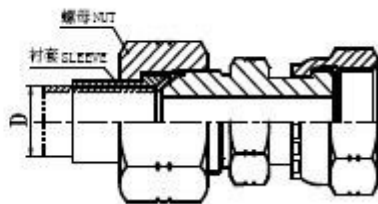
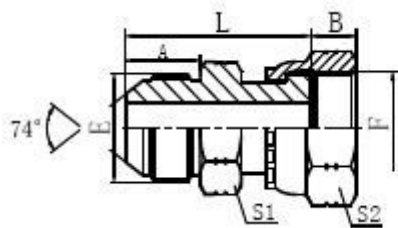

2JF

JIC 外螺纹 74°内锥/ORFS 内螺纹

JIC MALE 74° CONE/ORFS FEMALE

代号 P/N	螺纹 Thread		O 形圈 O-RING		尺寸 DIMENSIONS				
	E	F	E END	F END	A	B	L	S1	S2
2JF-04	7/16"X2	9/16X1			14	8.5	35.5	14	19
2JF-06	9/16"X1	11/16"X			14.1	10	38.5	17	22
2JF-08	3/4"X16	13/16"X			16.7	11	45	22	27
2JF-10	7/8"X14	1"X14			19.3	13.5	51.5	24	30
2JF-12	1.1/16"X1	1.3/16"X			21.9	15	58	30	36
2JF-16	1.5/16"X1	1.7/16"X			23.1	15	62	36	41

2JF-20	1.5/8"X1	1.11/16"			24.3	15	64.5	46	50
--------	----------	----------	--	--	------	----	------	----	----

Note: Nut and sleeve should be ordered separately. The nut NB200 and sleeve NB500 is suitable for metric tube, the nut NB200 and sleeve NB300 is suitable for inch tube.

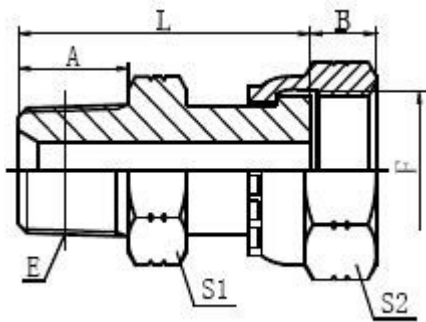

2NF 美制布锥管外螺纹/ORFS 内螺纹

NPT MALE/ORFS FEMALE

代号 P/N	螺纹 Thread		O 形圈 O-RING		尺寸 DIMENSIONS				
	E	F	E END	F END	A	B	L	S1	S2
2NF-02-04	Z1/8"X27	9/16"X18			10.5	8.5	32	14	19
2NF-04	Z1/4"X18	9/16"X18			15	8.5	36.5	17	19
2NF-04-06	Z1/4"X18	11/16"X16			15	10	39.5	17	22
2NF-06	Z3/8"X18	11/16"X16			16	10	40.5	19	22

2NF-06-08	Z3/8"X18	13/16"X16			16	11	42.5	19	27
2NF-08	Z1/2"X14	13/16"X16			19.5	11	48	22	27
2NF-08-10	Z1/2"X14	1"X14			19.5	13	52	24	30
2NF-12	Z3/4"X14	1.3/16"X12			19.5	15	55.5	30	36
2NF-12-16	Z3/4"X14	1.7/16"X12			19.5	15	58.5	36	41
2NF-16	Z1"X11.5	1.7/16"X12			25.5	15	64.5	36	41
2NF-16-20	Z1"X11.5	1.11/16"X1			25.5	15	66	41	50
2NF-20	Z1.1/4"X11.5	1.11/16"X1			26.5	15	67	46	50
2NF-24	Z1.1/2"X11.5	2"X12			27.5	15	72.5	50	60

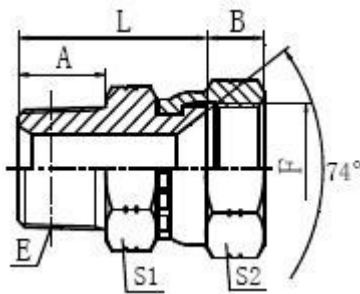

2NJ

布锥管外螺纹/JIC 内螺纹 74°内锥

NPT MALE/JIC FEMALE 74° SEAT

代号 P/N	螺纹 Thread		O 形圈 O-RING		尺寸 DIMENSIONS				
	E	F	E END	F END	A	B	L	S1	S2
2NJ-02-04	Z1/8"X27	7/16"X20			10.5	9	24.5	12	17
2NJ-02-05	Z1/8"X27	1/2"X20			10.5	9	25	12	17
2NJ-04	Z1/4"X18	7/16"X20			15	9	29	17	17

2NJ-04-06	Z1/4"X18	9/16"X18			15	10.5	29.5	17	19
2NJ-04-08	Z1/4"X18	3/4"X16			15	10.5	31.5	19	24
2NJ-06	Z3/8"X18	9/16"X18			16	10.5	30.5	19	19
2NJ-06-08	Z3/8"X18	3/4"X16			16	10.5	32.5	19	24
2NJ-06-10	Z3/8"X18	7/8"X14			16	12	35	22	27
2NJ-08	Z1/2"X14	3/4"X16			19.5	10.5	37.5	22	24
2NJ-08-06	Z1/2"X14	9/16"X18			19.5	10.5	36	22	19
2NJ-08-12	Z1/2"X14	1.1/16"X12			19.5	15	42	27	32
2NJ-12	Z3/4"X14	1.1/16"X12			19.5	15	42	30	32
2NJ-12-08	Z3/4"X14	3/4"X16			19.5	10.5	40	30	24
2NJ-12-10	Z3/4"X14	7/8"X14			19.5	12	40.5	30	27
2NJ-12-16	Z3/4"X14	1.5/16"X12			19.5	16	42.5	32	41
2NJ-16	Z1"X11.5	1.5/16"X12			25.5	16	48	36	41
2NJ-16-12	Z1"X11.5	1.1/16"X12			25.5	15	49	36	32
2NJ-16-20	Z1"X11.5	1.5/8"X12			25.5	17	52.5	41	50
2NJ-20	Z1.1/4"X11.5	1.5/8"X12			26.5	17	52.5	46	50
2NJ-20-24	Z1.1/4"X11.5	1.7/8"X12			26.5	20	54	46	60
2NJ-24-20	Z1.1/2"X11.5	1.5/8"X12			27.5	17	56.5	50	50
2NJ-24	Z1.1/2"X11.5	1.7/8"X12			27.5	23.5	57	50	60

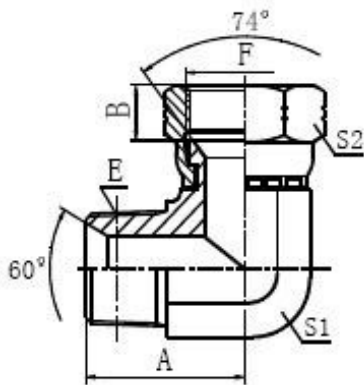

2NJ9

90°美制布锥管外螺纹/JIC 内螺纹 74°内锥

90°NPT MALE/JIC FEMALE 74° SEAT

代号 P/N	螺纹 Thread		O 形圈 O-RING		尺寸 DIMENSIONS				
	E	F	E END	F END	A	B	S1	S2	
2NJ9-04	Z1/4"X18	7/16"X20			25.5	9	14	17	
2NJ9-04-06	Z1/4"X18	9/16"X18			25.5	10.5	14	19	
2NJ9-06	Z3/8"X18	9/16"X18			31	10.5	19	19	
2NJ9-06-08	Z3/8"X18	3/4"X16			31	10.5	19	24	
2NJ9-08	Z1/2"X14	3/4"X16			37.3	10.5	22	24	
2NJ9-08-10	Z1/2"X14	7/8"X14			37.3	12	22	27	
2NJ9-08-12	Z1/2"X14	1.1/16"X12			37.5	15	24	32	
2NJ9-12	Z3/4"X14	1.1/16"X12			44	15	27	32	
2NJ9-12-08	Z3/4"X14	3/4"X16			43.5	10.5	27	24	
2NJ9-12-10	Z3/4"X14	7/8"X14			43.5	12	27	27	
2NJ9-16	Z1"X11.5	1.5/16"X12			50	16	33	41	
2NJ9-16-14	Z1"X11.5	1.3/16"X12			49	15	33	36	
2NJ9-20	Z1.1/4"X11.5	1.5/8"X12			53	17	41	50	

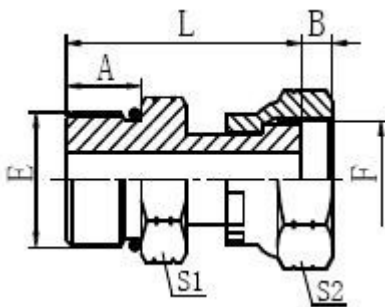

2OF

SAE 外螺纹带 O 形圈/ORFS 内螺纹

SAE O-RING BOSS/ORFS FEMALE

代号 P/N	螺纹 Thread		O 形圈 O-RING		尺寸 DIMENSIONS				
	E	F	E END	F END	A	B	L	S1	S2
2OF-04	7/16"X20	9/16"X18	8.92X1.83		11	8.5	32.5	17	19
2OF-06	9/16"X18	11/16"X16	11.89X1.9		12	10	36.5	19	22
2OF-08	3/4"X16	13/16"X16	16.36X2.2		14	11	42.5	22	27
2OF-10	7/8"X14	1"X14	19.18X2.4		16	13	50.5	27	30
2OF-12	1.1/16"X12	1.3/16"X12	23.47X2.9		18.5	15	56	32	36
2OF-16	1.5/16"X12	1.7/16"X12	29.74X2.9		18.5	14.8	57.5	38	41

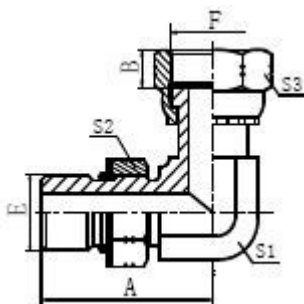

2OF9-OG

90° SAE 外螺纹带 O 形圈/ORFS 内螺纹

90° SAE O-RING BOSS/ORFS FEMALE

代号 P/N	螺纹 Thread		O 形圈 O-RING		尺寸 DIMENSIONS				
	E	F	E END	F END	A	B	L	S1	S2
2OF9-04OG	7/16"X20	9/16"X18	8.92X1.83		30	25	14	19	17
2OF9-06OG	9/16"X18	11/16"X16	11.89X1.98		34.5	28.5	16	22	19

2OF9-08OG	3/4"X16	13/16"X16	16.36X2.21		37.5	33	19	27	24
2OF9-10OG	7/8"X14	1"X14	19.18X2.46		45.2	38	22	30	27
2OF9-12OG	1.1/16"X12	1.3/16"X12	23.47X2.95		52	44	27	36	32
2OF9-16OG	1.5/16"X12	1.7/16"X12	29.74X2.95		56	49	33	41	41

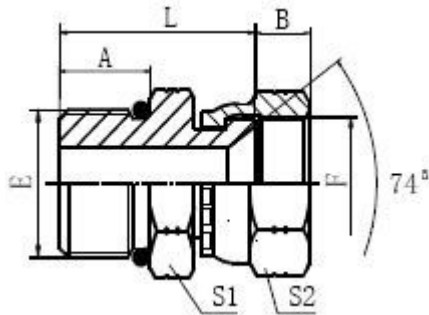

20J

SAE 外螺纹带 O 形圈/JIC 内螺纹 74°内锥

SAE O-RING BOSS/JIC FEMALE 74°SEAT

代号 P/N	螺纹 Thread		O 形圈 O-RING		尺寸 DIMENSIONS				
	E	F	E END	F END	A	B	L	S1	S2
20J-04	7/16"X20	7/16"X20	8.92x1.83		9.1	9	23	14	15
20J-05	1/2"X20	1/2"X20	10.52x1.83		9.1	9	23.5	17	17
20J-05-04	1/2"X20	7/16"X20	10.52x1.83		9.1	9	23	17	15
20J-06	9/16"X18	9/16"X18	11.89x1.98		9.9	10.5	24.5	17	19
20J-06-04	9/16"X18	7/16"X20	11.89x1.98		9.9	9	24	17	15
20J-06-08	9/16"X18	3/4"X16	11.89x1.98		9.9	10.5	26	19	24
20J-08	3/4"X16	3/4"X16	16.36x2.21		11.1	10.5	29.5	22	24
20J-08-06	3/4"X16	9/16"X18	16.36x2.21		11.1	10.5	27.5	22	19
20J-10	7/8"X14	7/8"X14	19.18x2.46		12.7	12	34	27	27
20J-10-08	7/8"X14	3/4"X16	19.18x2.46		12.7	10.5	33	27	24
20J-12	1.1/16"X12	1.1/16"X12	23.47x2.95		15.1	15	38.5	32	32
20J-12-08	1.1/16"X12	3/4"X16	23.47x2.95		15.1	10.5	36.5	32	24
20J-12-10	1.1/16"X12	7/8"X14	23.47x2.95		15.1	12	37	32	27

2OJ-12-16	1.1/16"X12	1.5/16"X12	23.47x2.95		15.1	16	38.5	32	41
2OJ-14	1.3/16"X12	1.3/16"X12	26.62x2.95		15.1	15	38.5	36	36
2OJ-16	1.5/16"X12	1.5/16"X12	29.74x2.95		15.1	16	38.5	38	41
2OJ-16-12	1.5/16"X12	1.1/16"X12	29.74x2.95		15.1	15	38.5	38	32
2OJ-16-14	1.5/16"X12	1.3/16"X12	29.74x2.95		15.1	15	38.5	38	36
2OJ-20	1.5/8"X12	1.5/8"X12	37.46x3.00		15.1	17	44	50	50
2OJ-24	1.7/8"X12	1.7/8"X12	43.69x3.00		15.1	20	44.5	55	55
2OJ-32	2.1/2"X12	2.1/2"X12	59.36X3.0		15.1	24.5	47	70	75

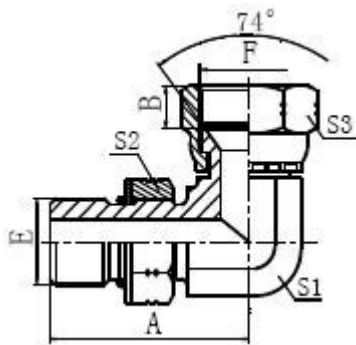

2OJ9-OG

90° SAE 外螺纹带 O 形圈/JIC 内螺纹 74°内锥

90° SAE O-RING BOSS/JIC FEMALE 74°SEAT

代号 P/N	螺纹 Thread		O 形圈 O-RING		尺寸 DIMENSIONS				
	E	F	E END	F END	A	B	S1	S2	S3
2OJ9-06OG	9/16"X18	9/16"X18	11.89X1.98		31.8	10.5	14	19	19
2OJ9-06-08OG	9/16"X18	3/4"X16	11.89X1.98		33.3	11	16	19	24
2OJ9-08OG	3/4"X16	3/4"X16	16.36X2.21		36.8	11	19	24	24
2OJ9-08-10OG	3/4"X16	7/8"X14	16.36X2.21		36.8	13	19	24	27
2OJ9-10OG	7/8"X14	7/8"X14	19.18X2.46		44	13	22	27	27
2OJ9-12OG	1.1/16"X12	1.1/16"X12	23.47X2.95		51	15	27	32	32
2OJ9-16OG	1.5/16"X12	1.5/16"X12	29.74X2.95		54.5	16	33	41	41

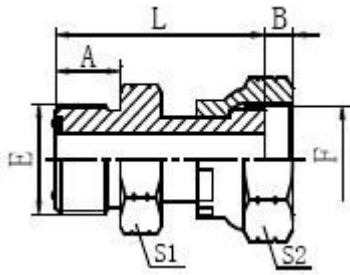

2F

ORFS 外螺纹/ORFS 内螺纹

ORFS MALE/ORFS FEMALE

代号 P/N	螺纹 Thread		O 形圈 O-RING		尺寸 DIMENSIONS				
	E	F	E END	F END	A	B	L	S1	S2
2F-04	9/16"X18	9/16"X18	7.65X1.78		10	8.5	31.3	17	19
2F-04-06	9/16"X18	11/16"X16	7.65X1.78		10	10	34.5	17	22
2F-04-08	9/16"X18	13/16"X16	7.65X1.78		10	11	36.5	19	27
2F-04-10	9/16"X18	1"X14	7.65X1.78		10	13.5	42.5	24	30
2F-04-12	9/16"X18	1.3/16"X12	7.65X1.78		10	15	46	30	36
2F-06	11/16"X16	11/16"X16	9.25X1.78		11.2	10	35.7	19	22
2F-06-08	11/16"X16	13/16"X16	9.25X1.78		11.2	11	37.7	19	27
2F-06-10	11/16"X16	1"X14	9.25X1.78		11.2	13.5	43.7	24	30
2F-06-12	11/16"X16	1.3/16"X12	9.25X1.78		11.2	15	47.2	30	36
2F-08	13/16"X16	13/16"X16	12.42X1.7		13	11	41.5	22	27
2F-08-10	13/16"X16	1"X14	12.42X1.7		13	13.5	45.5	24	30
2F-08-12	13/16"X16	1.3/16"X12	12.42X1.7		13	15	49	30	36
2F-08-16	13/16"X16	1.7/16"X12	12.42X1.7		13	15	52	36	41
2F-10-12	1"X14	1.3/16"X12	15.6X1.78		15.5	15	51.5	30	36
2F-10-16	1"X14	1.7/16"X12	15.6X1.78		15.5	15	56	36	41
2F-12-16	1.3/16"X12	1.7/16"X12	18.77X1.7		17	15	58	36	41

2F-12-20	1.3/16"X12	1.11/16"X1	18.77X1.7		17	15	57.5	41	50
2F-16-20	1.7/16"X12	1.11/16"X1	23.52X1.7		17.5	15	58	41	50
2F-16-24	1.7/16"X12	2"X12	23.52X1.7		17.5	16	61.5	50	60
2F-20-16	1.11/16"X12	1.7/16"X12	29.87X1.7		17.5	15	58.5	46	41
2F-20-24	1.11/16"X12	2"X12	29.87X1.7		17.5	16	61.5	50	60
2F-24	2"X12	2"X12	37.82X1.7		17.5	16	61.5	55	60

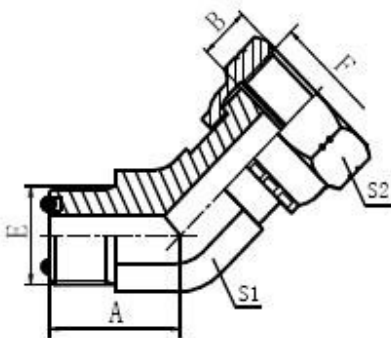

2F4

45° ORFS 外螺纹/ORFS 内螺纹

45° ORFS MALE/ORFS FEMALE

代号 P/N	螺纹 Thread		O 形圈 O-RING		尺寸 DIMENSIONS				
	E	F	E END	F END	A	B	S1	S2	
2F4-04	9/16X18	9/16X18	7.65X1.78		18.3	8.5	14	19	
2F4-06	11/16"X16	11/16"X16	9.25X1.78		20.5	10	19	22	
2F4-08	13/16"X16	13/16"X16	12.42X1.78		24	11	22	27	
2F4-10	1"X14	1"X14	15.6X1.78		28	15	27	30	
2F4-12	1.3/16"X12	1.3/16"X12	18.77X1.78		30.7	15	30	36	
2F4-16	1.7/16"X12	1.7/16"X12	23.52X1.78		33	15	36	41	
2F4-20	1.11/16"X12	1.11/16"X12	29.87X1.78		35.5	15	41	50	

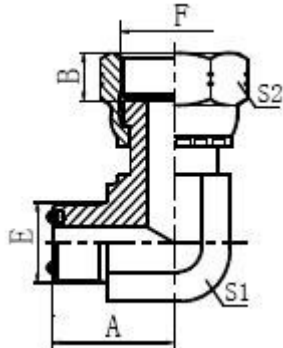

2F9

90°美制 ORFS 外螺纹/ORFS 内螺纹

90° ORFS MALE/ORFS FEMALE

代号 P/N	螺纹 Thread		O 形圈 O-RING		尺寸 DIMENSIONS				
	E	F	E END	F END	A	B	S1	S2	
2F9-04	9/16X18	9/16X18	7.65X1.78		23	8.5	14	19	
2F9-06	11/16"X16	11/16"X16	9.25X1.78		27.5	10	19	22	
2F9-08	13/16"X16	13/16"X16	12.42X1.78		31	11	22	27	
2F9-10	1"X14	1"X14	15.6X1.78		36.5	15	27	30	
2F9-12	1.3/16"X12	1.3/16"X12	18.77X1.78		41	15	30	36	
2F9-16	1.7/16"X12	1.7/16"X12	23.52X1.78		48	15	41	41	
2F9-20	1.11/16"X12	1.11/16"X1	29.87X1.78		47.5	15	41	50	

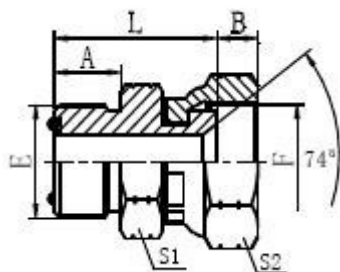

螺纹

2FJ 美制 ORFS 外螺纹/ORFS 内

ORFS MALE/ORFS FEMALE

代号 P/N	螺纹 Thread		O 形圈 O-RING		尺寸 DIMENSIONS				
	E	F	E END	F END	A	B	L	S1	S2

2FJ-04	9/16X18	7/16"X2	7.65X1.7		10	9	24	17	17
2FJ-06	11/16"X1	9/16"X1	9.25X1.7		11.2	10.5	26	19	19
2FJ-08	13/16"X1	3/4"X16	12.42X1.		13	10.5	31.5	22	24
2FJ-12	1.3/16"X1	1.1/16"X1	18.77X1.		17	15	40.5	32	32

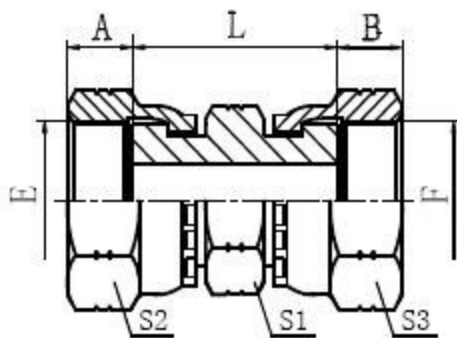

3F

美制 ORFS 内螺纹平面

ORFS FEMALE FLAT

代号 P/N	螺纹 Thread		O 形圈 O-RING		尺寸 DIMENSIONS				
	E	F	E END	F END	A	B	L	S1	S2
3F-04	9/16"X18	9/16"X18			8.5	8.5	33.5	19	19
3F-06	11/16"X16	11/16"X16			10	10	40.5	22	22
3F-08	13/16"X16	13/16"X16			11	11	44.5	27	27
3F-10	1"X14	1"X14			13.5	13.5	52.5	30	30
3F-12	1.3/16"X12	1.3/16"X12			15	15	56	36	36
3F-16	1.7/16"X12	1.7/16"X12			15	15	60	41	41
3F-20	1.11/16"X12	1.11/16"X12			15	15	59.5	50	50
3F-24	2"X12	2"X12			16	16	64	60	60

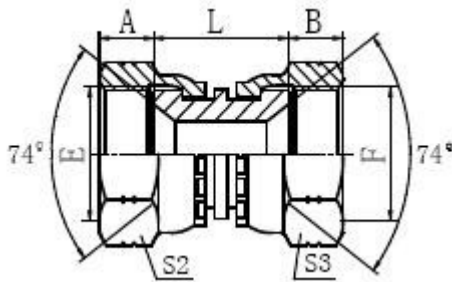

3J

美制 JIC 内螺纹 74°内锥

JIC FEMALE 74° SEAT

代号 P/N	螺纹 Thread		O 形圈 O-RING		尺寸 DIMENSIONS				
	E	F	E END	F END	A	B	L	S1	S3
3J-04	7/16"X20	7/16"X20			9	9	19	15	15
3J-05	1/2"X20	1/2"X20			9.5	9.5	21	17	17
3J-06	9/16"X18	9/16"X18			10.5	10.5	21	19	19
3J-08	3/4"X16	3/4"X16			11	11	26	24	24
3J-10	7/8"X14	7/8"X14			13	13	27	27	27
3J-12	1.1/16"X12	1.1/16"X12			15	15	29	32	32
3J-16	1.5/16"X12	1.5/16"X12			16	16	29	41	41
3J-20	1.5/8"X12	1.5/8"X12			17	17	33	50	50
3J-24	1.7/8"X12	1.7/8"X12			20	20	35.5	55	55

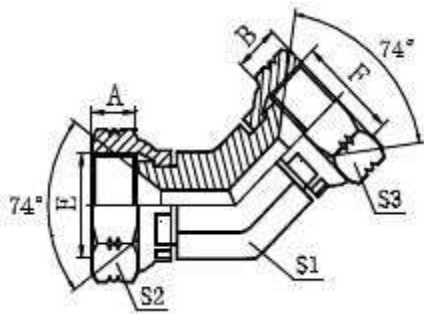

3J4

45° JIC 内螺纹 74°内锥

45° JIC FEMALE 74° SEAT

代号 P/N	螺纹 Thread		O 形圈 O-RING		尺寸 DIMENSIONS				
	E	F	E END	F END	A	B	S1	S2	S3
3J4-04	7/16"x20	7/16"x20			9	9	11	15	15
3J4-05	1/2"x20	1/2"x20			9.5	9.5	11	17	17
3J4-06	9/16"x18	9/16"x18			10.5	10.5	14	19	19
3J4-08	3/4"x16	3/4"x16			11	11	16	24	24
3J4-10	7/8"x14	7/8"x14			13	13	19	27	27
3J4-12	1.1/16"x12	1.1/16"x12			15	15	24	32	32
3J4-16	1.5/16"x12	1.5/16"x12			16	16	30	41	41

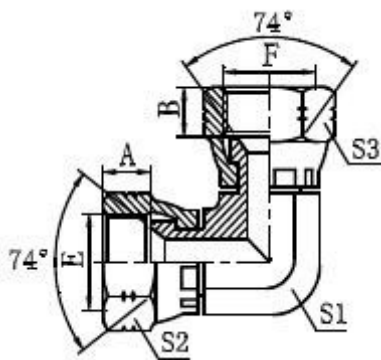

3J9

90° 美制 JIC 内螺纹 74° 内锥

90° JIC FEMALE 74° SEAT

代号 P/N	螺纹 Thread		O 形圈 O-RING		尺寸 DIMENSIONS				
	E	F	E END	F END	A	B	S1	S2	S3
3J9-04	7/16"X20	7/16"X20			9	9	11	15	15
3J9-05	1/2"X20	1/2"X20			9.5	9.5	14	17	17
3J9-06	9/16"X18	9/16"X18			10.5	10.5	14	19	19

3J9-08	3/4"X16	3/4"X16			11	11	19	24	24
3J9-12	1.1/16"X12	1.1/16"X12			15	15	27	32	32
3J9-16	1.5/16"X12	1.5/16"X12			16	16	33	41	41

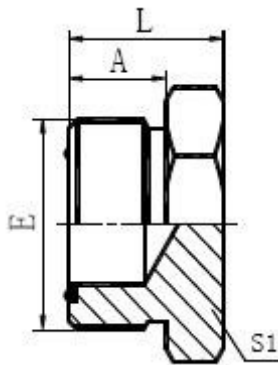

4F

美制 ORFS 外螺纹堵头

ORFS MALE PLUG

代号 P/N	螺纹 Thread		O 形圈 O-RING		尺寸 DIMENSIONS				
	E	F	E END	F END	A	L	S1		
4F-04	9/16"X18		7.65X1.78		9.8	16.8	17		
4F-06	11/16"X16		9.25X1.78		11.2	19.2	19		
4F-08	13/16"X16		12.42X1.78		12.8	21.8	22		
4F-10	1"X14		15.6X1.78		15.5	25.9	27		
4F-12	1.3/16"X12		18.77X1.78		17	27.4	32		
4F-16	1.7/16"X12		23.52X1.78		17.5	27.9	38		
4F-20	1.11/16"X12		29.87X1.78		17.5	27.9	46		
4F-24	2"X12		37.82X1.78		17.5	27.9	55		

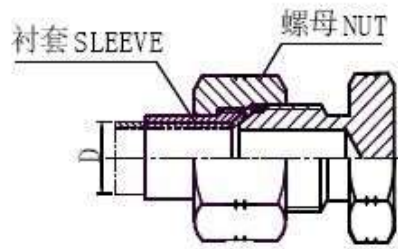
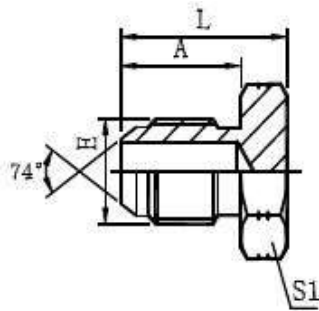

4J

美制 JIC 外螺纹 74°外锥堵头

JIC MALE 74° CONE PLUG

代号 P/N	螺纹 Thread		O 形圈 O-RING		尺寸 DIMENSIONS				
	E	F	E END	F END	A	L	S1		
4J-04	7/16"X20				14	20	12		
4J-05	1/2"X20				14	20	14		
4J-06	9/16"X18				14.1	20	17		
4J-08	3/4"X16				16.	25	22		
4J-10	7/8"X14				19.	27.	24		
4J-12	1.1/16"X12				21.	32	30		
4J-16	1.5/16"X12				23.	34	36		
4J-20	1.5/8"X12				24.	38	46		
4J-24	1.7/8"X12				27.	44.	50		
4J-32	2.1/2"X12				33.	51	65		

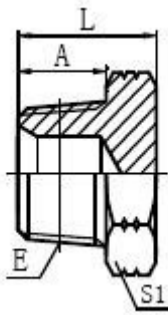

4N 美制布锥管外螺纹堵头

NPT MALE PLUG

代号 P/N	螺纹 Thread		O形圈 O-RING		尺寸 DIMENSIONS				
	E	F	E END	F END	A	L	S1		
4N-02	Z1/8"X27				10.5	16	12		
4N-04	Z1/4"X18				15	20	17		
4N-06	Z3/8"X18				16	21	19		
4N-08	Z1/2"X14				19.5	27	22		
4N-12	Z3/4"X14				19.5	29.5	30		
4N-16	Z1"X11.5				25.5	36.5	36		
4N-20	Z1.1/4"X11.5				26.5	38.5	46		
4N-24	Z1.1/2"X11.5				27.5	43	50		
4N-32	Z2"X11.5				27.5	43.5	65		

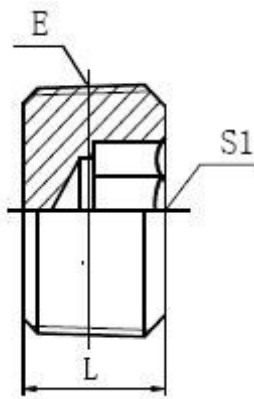

4NN

美布锥管外螺纹内六角堵头

NPT MALE HOLLOW HEX PLUG

代号 P/N	螺纹 Thread		O 形圈 O-RING		尺寸 DIMENSIONS				
	E	F	E END	F END	A	L	S1		
4NN-02	Z1/8"X27				8	5			
4NN-04	Z1/4"X18				10	6			
4NN-06	Z3/8"X18				12	8			
4NN-08	Z1/2"X14				15	10			
4NN-12	Z3/4"X14				16	12			
4NN-16	Z1"X11.5				18	17			

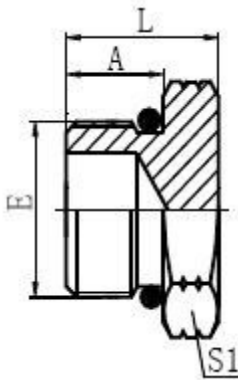

4O 美制 SAE 外螺纹带 O 形圈堵头

SAE O-RING BOSS PLUG

代号 P/N	螺纹 Thread		O 形圈 O-RING		尺寸 DIMENSIONS				
	E	F	E END	F END	A	L	S1		
4O-04	7/16"X20		8.92X1.83		9.1	16	14		
4O-05	1/2"X20		10.52X1.83		9.1	16	17		
4O-06	9/16"X18		11.89X1.98		9.9	17.5	17		
4O-08	3/4"X16		16.36X2.21		11.1	19.5	22		
4O-10	7/8"X14		19.18X2.46		12.7	23	27		
4O-12	1.1/16"X12		23.47X2.95		15.1	26.5	32		
4O-14	1.3/16"X12		26.62X2.95		15.1	27	36		
4O-16	1.5/16"X12		29.74X2.95		15.1	27.5	38		
4O-20	1.5/8"X12		37.46X3.00		15.1	30	50		
4O-24	1.7/8"X12		43.69X3.00		15.1	30	55		
4O-32	2.1/2"X12		59.36X3.00		15.1	32	70		

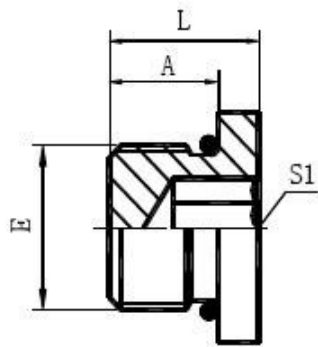

4ON

SAE 外螺纹内六角堵头

SAE O-RING BOSS HOLLOW HEX PLUG

代号 P/N	螺纹 Thread		O 形圈 O-RING		尺寸 DIMENSIONS				
	E	F	E END	F END	A	L	S1		
4ON-04	7/16"X20		8.92X1.83		9.1	11.5	5		
4ON-05	1/2"X20		10.52X1.83		9.1	11.5	5		
4ON-06	9/16"X18		11.89X1.98		9.9	12.2	6		
4ON-08	3/4"X16		16.36X2.21		11.1	14.3	8		
4ON-10	7/8"X14		19.18X2.46		12.7	16	10		
4ON-12	1.1/16"X12		23.47X2.95		15.1	19	14		
4ON-16	1.5/16"X12		29.74X2.95		15.1	19	17		

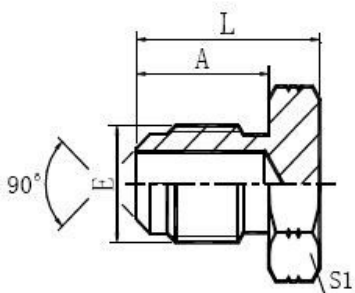

4P 美制 SAE 外螺纹 90°

外锥堵头

SAE MALE 90° CONE PLUG

代号 P/N	螺纹 Thread		O 形圈 O-RING		尺寸 DIMENSIONS				
	E	F	E END	F END	A	L	S1		
4P-04	7/16"X20				12.7	18.5	14		
4P-05	1/2"X20				14.2	20	14		
4P-06	5/8"X18				15.7	22	17		

4P-08	3/4"X16				19	27	22		
4P-10	7/8"X14				22.4	30.5	24		
4P-12	1.1/16"X14				25.4	35.5	30		

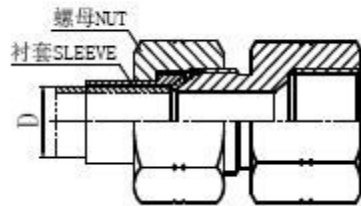
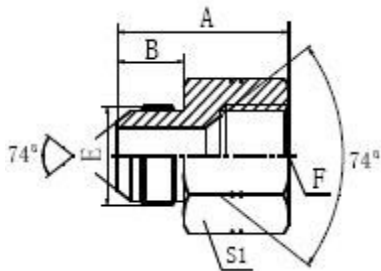

5J

JIC 外螺纹 74° 外锥/JIC 内螺纹 74° 内锥

JIC MALE 74° CONE/JIC FEMALE 74° SEAT

代号 P/N	螺纹 Thread		O 形圈 O-RING		尺寸 DIMENSIONS				
	E	F	E END	F END	A	B	S1		
5J-04-05	7/16"X20	1/2"X20			30.6	14	17		
5J-05-06	1/2"X20	9/16"X18			33.7	14	19		
5J-06-04	9/16"X18	7/16"X20			30.6	14.1	17		
5J-08-10	3/4"X16	7/8"X14			36.2	16.7	30		
5J-10-12	7/8"X14	1.1/16"X12			45.1	19.3	32		
5J-12-10	1.1/16"X12	7/8"X14			43	21.9	30		
5J-16-12	1.5/16"X12	1.1/16"X12			50	23.1	36		

Note: Nut and sleeve should be ordered separately. The nut NB200 and sleeve NB500 is suitable for metric tube, the nut NB200 and sleeve NB300 is suitable for inch tube.

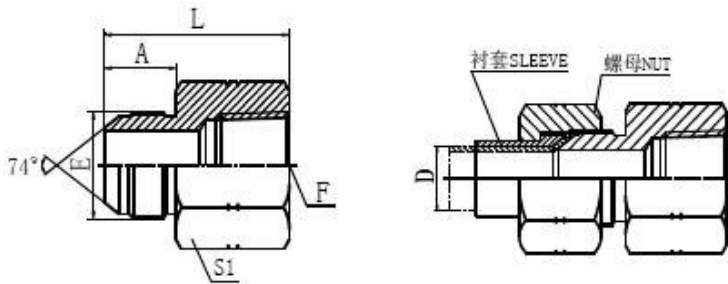

5JN

JIC 外螺纹 74° 外锥/布锥管内螺纹

JIC MALE 74° CONE/NPT FEMALE

代号 P/N	螺纹 Thread		尺寸 DIMENSIONS			
	E	F	A	L	S1	
5JN-04-02	7/16"X20	Z1/8"X27	14	30.2	14	
5JN-04	7/16"X20	Z1/4"X18	14	35.3	19	
5JN-05-02	1/2"X20	Z1/8"X27	14	29.7	14	
5JN-05-04	1/2"X20	Z1/4"X18	14	35.3	19	
5JN-06-02	9/16"X18	Z1/8"X27	14.1	30.1	17	
5JN-06-04	9/16"X18	Z1/4"X18	14.1	35.6	19	
5JN-06	9/16"X18	Z3/8"X18	14.1	37.1	22	
5JN-06-08	9/16"X18	Z1/2"X14	14.1	42.5	30	
5JN-08-06	3/4"X16	Z3/8"X18	16.7	39.6	22	
5JN-08	3/4"X16	Z1/2"X14	16.7	45.6	30	
5JN-08-12	3/4"X16	Z3/4"X14	16.7	45	36	
5JN-10-08	7/8"X14	Z1/2"X14	19.3	48	30	
5JN-10-12	7/8"X14	Z3/4"X14	19.3	49.7	36	
5JN-12-08	1.1/16"X12	Z1/2"X14	21.9	52.1	30	
5JN-12	1.1/16"X12	Z3/4"X14	21.9	52.3	36	
5JN-14-12	1.3/16"X12	Z3/4"X14	22.6	49.5	36	
5JN-16-12	1.5/16"X12	Z3/4"X14	23.1	50	36	
5JN-16	1.5/16"X12	Z1"X11.5	23.1	59.7	41	
5JN-20-12	1.5/8"X12	Z3/4"X14	24.3	46.6	46	
5JN-20	1.5/8"X12	Z1.1/4"X11.5	24.3	63.2	50	
5JN-24-16	1.7/8"X12	Z1"X11.5	27.5	54.1	50	
5JN-24-20	1.7/8"X12	Z1.1/4"X11.5	27.5	62	50	

5JN-24	1.7/8"X12	Z1.1/2"X11.5	27.5	66.5	60	
5JN-32-24	2.1/2"X12	Z1.1/2"X11.5	33.9	51	65	
5JN-32	2.1/2"X12	Z2"X11.5	33.9	70	70	

Note: Nut and sleeve should be ordered separately. The nut NB200 and sleeve NB500 is suitable for metric tube, the nut NB200 and sleeve NB300 is suitable for inch tube.

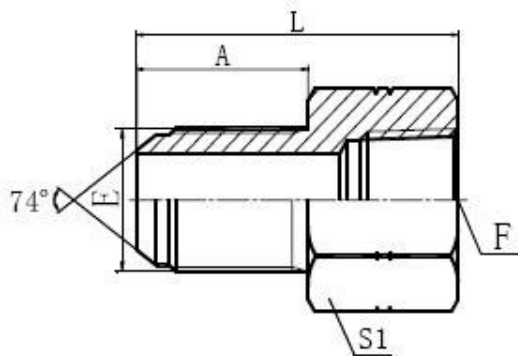

5JN-L

JIC 外螺纹 74° 外锥/布锥管内螺纹

JIC MALE 74° CONE/NPT FEMALE

代号 P/N	螺纹 Thread		尺寸 DIMENSIONS			
	E	F	A	L	S1	
5JN-04-02L	7/16"X20	Z1/8"X27	32.5	48.5	17	
5JN-04L	7/16"X20	Z1/4"X18	32.5	54	19	
5JN-06-04L	9/16"X18	Z1/4"X18	32.5	54	19	
5JN-10-08L	7/8"X14	Z1/2"X14	40.1	68.5	30	
5JN-12L	1.1/16"X12	Z3/4"X14	44.5	75	36	
5JN-16L	1.5/16"X12	Z1"X11.5	44.5	81	41	

JIC 外螺纹 74° 外
锥/布锥管内螺纹

90° JIC MALE

74°

CONE/NPT

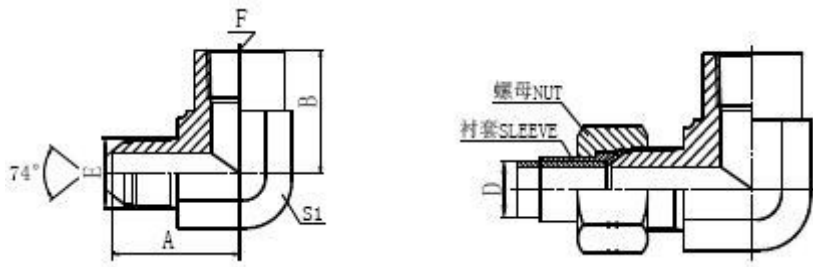

FEMALE

代号 P/N	螺纹 Thread		尺寸 DIMENSIONS			
	E	F	A	B	S1	
5JN9-04	7/16"X20	Z1/4"X18	30.9	22.4	19	
5JN9-04-02	7/16"X20	Z1/8"X27	27.5	16.8	16	
5JN9-05-02	1/2"X20	Z1/8"X27	27.5	16.8	16	
5JN9-05-04	1/2"X20	Z1/4"X18	30.9	22.4	19	
5JN9-06	9/16"X18	Z3/8"X18	33.5	25.9	24	
5JN9-06-02	9/16"X18	Z1/8"X27	28.5	17.3	16	
5JN9-06-04	9/16"X18	Z1/4"X18	31.2	22.4	19	
5JN9-08	3/4"X16	Z1/2"X14	39.5	31.2	30	
5JN9-08-04	3/4"X16	Z1/4"X18	31.6	22.4	19	
5JN9-08-06	3/4"X16	Z3/8"X18	36	25.9	24	
5JN9-10-06	7/8"X14	Z3/8"X18	39.5	25	24	
5JN9-10-08	7/8"X14	Z1/2"X14	42.5	31.2	30	
5JN9-12	1.1/16"X12	Z3/4"X14	48	34.5	33	
5JN9-12-08	1.1/16"X12	Z1/2"X14	46	31.2	30	

5JN9-12-16	1.1/16"X12	Z1"X11.5	52.5	41.1	41	
5JN9-16	1.5/16"X12	Z1"X11.5	55.1	41.1	41	
5JN9-16-12	1.5/16"X12	Z3/4"X14	49	34.5	33	
5JN9-20	1.5/8"X12	Z1.1/4"X11.5	59.2	43.2	48	
5JN9-24	1.7/8"X12	Z1.1/2"X11.5	73.4	52.8	63	

Note: Nut and sleeve should be ordered separately. The nut NB200 and sleeve NB500 is suitable for metric tube, the nut NB200 and sleeve NB300 is suitable for inch tube.

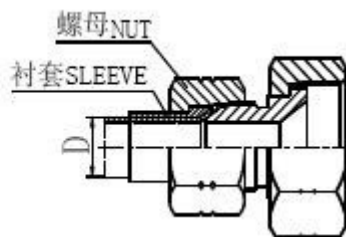
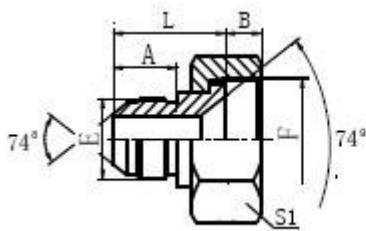

5J-S

美制 JIC 外螺纹/美制 JIC 内螺纹

JIC MALE/JIC
FEMALE

代号 P/N	螺纹 Thread		尺寸 DIMENSIONS			
	E	F	A	B	L	S1
5J-04-06S	7/16"X20	9/16"X18	14	9.8	26.2	19
5J-04-08S	7/16"x20	3/4"X16	14	10.9	26.2	24
5J-04-12S	7/16"X20	1.1/16"X12	14	15	29.8	32
5J-06-08S	9/16"X18	3/4"X16	14.1	10.9	26.3	24
5J-06-12S	9/16"X18	1.1/16"X12	14.1	15	30.1	32
5J-06-14S	9/16"X18	1.3/16"X12	14.1	15.2	32.5	36
5J-06-16S	9/16"X18	1.5/16"X12	14.1	15.9	33	38
5J-08-12S	3/4"X16	1.1/16"X12	16.7	15	33.3	32

5J-08-14S	3/4"X16	1.3/16"X12	16.7	15.2	35	36
5J-08-16S	3/4"X16	1.5/16"X12	16.7	15.9	35.6	38
5J-08-20S	3/4"X16	1.5/8"X12	16.7	16.8	35.5	50
5J-10-24S	7/8"X14	1.7/8"X12	19.3	19.7	42	60
5J-12-16S	1.1/16"X12	1.5/16"X12	22	15.9	40.2	38
5J-12-20S	1.1/16"X12	1.5/8"X12	22	16.8	40.6	50
5J-12-24S	1.1/16"X12	1.7/8"X12	22	19.7	42	60
5J-16-20S	1.5/16"X12	1.5/8"X12	23	16.8	41.8	50
5J-16-24S	1.5/16"X12	1.7/8"X12	23	19.7	43.2	60
5J-16-32S	1.5/16"X12	2.1/2"X12	23	29.1	49	75
5J-20-24S	1.5/8"X12	1.7/8"X12	24.3	19.7	44.3	60
5J-20-32S	1.5/8"X12	2.1/2"X12	24.3	29.1	50	75

Note: Nut and sleeve should be ordered separately. The nut NB200 and sleeve NB500 is suitable for metric tube, the nut NB200 and sleeve NB300 is suitable for inch tube.

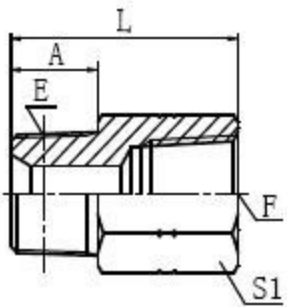

5N 布锥管外螺纹/布锥管内螺纹

NPT MALE/NPT FEMALE

代号 P/N	螺纹 Thread		尺寸 DIMENSIONS			
	E	F	A	L	S1	
5N-02	Z1/8"X27	Z1/8"X27	10.5	25.5	17	
5N-02-04	Z1/8"X27	Z1/4"X18	10.5	31	19	
5N-02-08	Z1/8"X27	Z1/2"X14	11	39	30	
5N-04-02	Z1/4"X18	Z1/8"X27	15	22	17	
5N-04	Z1/4"X18	Z1/4"X18	15	35.3	19	
5N-04-06	Z1/4"X18	Z3/8"X18	15	36.6	24	
5N-04-08	Z1/4"X18	Z1/2"X14	15	43	30	
5N-04-12	Z1/4"X18	Z3/4"X14	15	45	36	
5N-06-02	Z3/8"X18	Z1/8"X27	16	22	19	
5N-06-04	Z3/8"X18	Z1/4"X18	16	22	19	
5N-06	Z3/8"X18	Z3/8"X18	16	37.6	24	
5N-06-08	Z3/8"X18	Z1/2"X14	16.7	43.7	30	
5N-08-02	Z1/2"X14	Z1/8"X27	19.5	28.5	24	
5N-08-04	Z1/2"X14	Z1/4"X18	19.5	28	24	
5N-08-06	Z1/2"X14	Z3/8"X18	19.5	28.5	24	
5N-08	Z1/2"X14	Z1/2"X14	19.5	47.5	30	
5N-08-12	Z1/2"X14	Z3/4"X14	19.5	49	36	
5N-12-04	Z3/4"X14	Z1/4"X18	19.5	30	30	
5N-12-06	Z3/4"X14	Z3/8"X18	19.5	30.5	30	
5N-12-08	Z3/4"X14	Z1/2"X14	19.5	30.5	32	
5N-12	Z3/4"X14	Z3/4"X14	19.5	49	36	
5N-12-16	Z3/4"X14	Z1"X11.5	19.5	55.5	41	

5N-16-04	Z1"X11.5	Z1/4"X18	25.5	35.5	36	
5N-16-06	Z1"X11.5	Z3/8"X18	25.5	35.5	36	
5N-16-08	Z1"X11.5	Z1/2"X14	25.5	35.5	36	
5N-16-12	Z1"X11.5	Z3/4"X14	25.5	36.5	36	
5N-16	Z1"X11.5	Z1"X11.5	25.5	60.7	41	
5N-16-20	Z1"X11.5	Z1.1/4"X11.5	25.5	62.5	50	
5N-20-08	Z1.1/4"X11.5	Z1/2" X14	26.5	38.5	46	
5N-20-12	Z1.1/4"X11.5	Z3/4"X14	26.5	38.5	46	
5N-20-16	Z1.1/4"X11.5	Z1"X11.5	26.5	41	46	
5N-20	Z1.1/4"X11.5	Z1.1/4"X11.5	26.5	62.5	50	
5N-20-24	Z1.1/4"X11.5	Z1.1/2"X11.5	26.5	62.5	60	
5N-24-08	Z1.1/2"X11.5	Z1/2" X14	27.5	41	50	
5N-24-12	Z1.1/2"X11.5	Z3/4" X14	27.5	41	50	
5N-24-16	Z1.1/2"X11.5	Z1"X11.5	27.5	41.5	50	
5N-24-20	Z1.1/2"X11.5	Z1.1/4"X11.5	27.5	41	50	
5N-24	Z1.1/2"X11.5	Z1.1/2"X11.5	27.5	62.5	65	
5N-32-16	Z2"X11.5	Z1"X11.5	27.5	45	65	
5N-32-20	Z2"X11.5	Z1.1/4"X11.5	27.5	45	65	
5N-32-24	Z2"X11.5	Z1.1/2"X11.5	27.5	45	65	
5N-32	Z2"X11.5	Z2"X11.5	27.5	63.5	70	

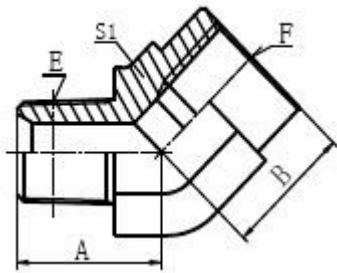

5N4

45°布锥管外螺纹/布锥管内螺纹

45° NPT MALE/NPT FEMALE

代号 P/N	螺纹 Thread		尺寸 DIMENSIONS			
	E	F	A	B	S1	
5N4-02	Z1/8"X27	Z1/8"X27	19	17	16	
5N4-04	Z1/4"X18	Z1/4"X18	22	20	19	
5N4-06	Z3/8"X18	Z3/8"X18	27	19	24	
5N4-08	Z1/2"X14	Z1/2"X14	31.7	28	30	
5N4-12	Z3/4"X14	Z3/4"X14	36.5	30	33	
5N4-16	Z1"X11.5	Z1"X11.5	42.5	37.5	41	

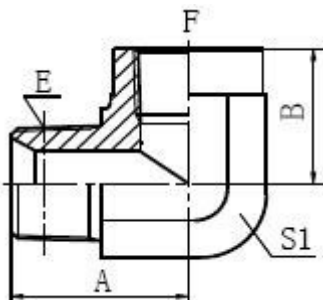

5N9

90°布锥管外螺纹/布锥管内螺纹

90° NPT MALE/NPT FEMALE

代号 P/N	螺纹 Thread		尺寸 DIMENSIONS			
	E	F	A	B	S1	
5N9-02	Z1/8"X27	Z1/8"X27	24.5	17.8	16	
5N9-02-04	Z1/8"X27	Z1/4"X18	26	22.4	19	
5N9-04-02	Z1/4"X18	Z1/8"X27	26.5	16.8	16	
5N9-04	Z1/4"X18	Z1/4"X18	28	22.4	19	
5N9-04-06	Z1/4"X18	Z3/8"X18	31	25	24	
5N9-06-04	Z3/8"X18	Z1/4"X18	31	22.4	19	
5N9-06	Z3/8"X18	Z3/8"X18	33.5	25	24	
5N9-06-08	Z3/8"X18	Z1/2"X14	38	31.2	30	
5N9-08	Z1/2"X14	Z1/2"X14	41.2	31.2	30	
5N9-08-06	Z1/2"X14	Z3/8"X18	37.5	25	24	
5N9-12-08	Z3/4"X14	Z1/2"X14	45	31.2	30	
5N9-12	Z3/4"X14	Z3/4"X14	45.2	34.5	33	
5N9-16-12	Z1"X11.5	Z3/4"X14	50	34.5	33	
5N9-16	Z1"X11.5	Z1"X11.5	54.5	41.1	41	
5N9-20-12	Z1.1/4"X11.5	Z3/4"X14	60	39.1	41	
5N9-20-16	Z1.1/4"X11.5	Z1"X11.5	60	41.1	41	
5N9-20	Z1.1/4"X11.5	Z1.1/4"X11.5	63	43.2	48	
5N9-20-24	Z1.1/4"X11.5	Z1.1/2"X11.5	71	52	63	
5N9-24-20	Z1.1/2"X11.5	Z1.1/4"X11.5	63	43.2	48	

5N9-24	Z1.1/2"X11.5	Z1.1/2"X11.5	71.5	52.8	63	
5N9-32	Z2"X11.5	Z2"X11.5	73.5	62	65	

5NO

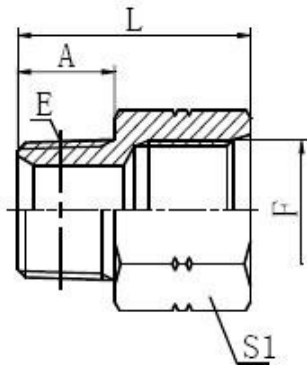

布锥管外螺纹/美制 SAE 内螺纹

NPT MALE/SAE FEMALE

代号 P/N	螺纹 Thread		尺寸 DIMENSIONS			
	E	F	A	L	S1	
5NO-02-04	Z1/8"X27	7/16"X20	10.5	29.5	17	
5NO-04	Z1/4"X18	7/16"X20	15	34	17	
5NO-04-06	Z1/4"X18	9/16"X18	15	36	19	
5NO-04-08	Z1/4"X18	3/4"X16	15	39	24	
5NO-06	Z3/8"X18	9/16"X18	16	34.5	19	
5NO-06-04	Z3/8"X18	7/16"X20	16	22	19	
5NO-06-08	Z3/8"X18	3/4"X16	16	40	24	
5NO-08	Z1/2"X14	3/4"X16	19.5	41.5	27	
5NO-08-04	Z1/2"X14	7/16"X20	19.5	27.5	22	
5NO-08-06	Z1/2"X14	9/16"X18	19.5	27.5	22	
5NO-08-10	Z1/2"X14	7/8"X14	19.5	42	30	
5NO-12	Z3/4"X14	1.1/16"X12	19.5	47	36	

5NO-12-06	Z3/4"X14	9/16"X18	19.5	30.5	30	
5NO-12-08	Z3/4"X14	3/4"X16	19.5	29.5	30	
5NO-12-10	Z3/4"X14	7/8"X14	19.5	42	30	
5NO-16	Z1"X11.5	1.5/16"X12	25.5	53	41	
5NO-16-06	Z1"X11.5	9/16"X18	25.5	36.5	36	
5NO-16-08	Z1"X11.5	3/4"X16	25.5	36.5	36	
5NO-16-10	Z1"X11.5	7/8"X14	25.5	36.5	36	
5NO-16-12	Z1"X11.5	1.1/16"X12	25.5	36.5	36	

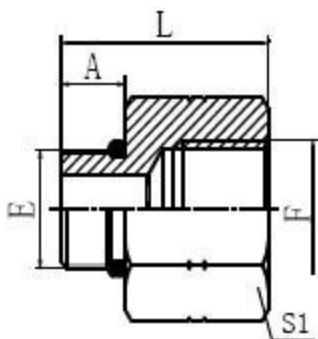

50

SAE 外螺纹带 O 形圈/SAE 内螺纹

SAE O-RING BOSS/SAE FEMALE

代号 P/N	螺纹 Thread		O RING	尺寸 DIMENSIONS		
	E	F	E END	A	L	S1
50-04-06	7/16"X20	9/16"X18	8.92X1.83	9.14	27	19
50-06-04	9/16"X18	7/16"X20	11.89X1.98	9.93	27	17
50-06-08	9/16"X18	3/4"X16	11.89X1.98	9.93	30.5	24
50-08-04	3/4"X16	7/16"X20	16.36X2.21	11.13	28.5	22
50-08-06	3/4"X16	9/16"X18	16.36X2.21	11.13	29	22
50-08-10	3/4"X16	7/8"X14	16.36X2.21	11.13	33.5	27
50-08-12	3/4"X16	1.1/16"X12	16.36X2.21	11.13	36	32

50-10	7/8"X14	7/8"X14	19.18X2.46	12.7	35.5	27
50-10-06	7/8"X14	9/16"X18	19.18X2.46	12.7	30.5	27
50-10-08	7/8"X14	3/4"X16	19.18X2.46	12.7	34	27
50-10-12	7/8"X14	1.1/16"X12	19.18X2.46	12.7	37.5	32
50-12-04	1.1/16"X12	7/16"X20	23.47X2.95	15.1	30	32
50-12-06	1.1/16"X12	9/16"X18	23.47X2.95	15.1	31	32
50-12-08	1.1/16"X12	3/4"X16	23.47X2.95	15.1	33	32
50-12-10	1.1/16"X12	7/8"X14	23.47X2.95	15.1	37.5	32
50-12-14	1.1/16"X12	1.3/16"X12	23.47X2.95	15.1	40	36
50-12-16	1.1/16"X12	1.5/16"X12	23.47X2.95	15.1	40	41
50-14-08	1.3/16"X12	3/4"X16	26.74X2.95	15.1	31	36
50-14-10	1.3/16"X12	7/8"X14	26.74X2.95	15.1	32.5	36
50-14-12	1.3/16"X12	1.1/16"X12	26.74X2.95	15.1	40	36
50-16-06	1.5/16"X12	9/16"X18	29.74X2.95	15.1	30	38
50-16-08	1.5/16"X12	3/4"X16	29.74X2.95	15.1	31.5	38
50-16-10	1.5/16"X12	7/8"X14	29.74X2.95	15.1	33	38
50-16-12	1.5/16"X12	1.1/16"X12	29.74X2.95	15.1	40	38
50-16-14	1.5/16"X12	1.3/16"X12	29.74X2.95	15.1	40	38
50-16-20	1.5/16"X12	1.5/8"X12	29.74X2.95	15.1	40	50
50-20-10	1.5/8"X12	7/8"X14	37.46X3.00	15.1	33	50
50-20-12	1.5/8"X12	1.1/16"X12	37.46X3.00	15.1	40	50
50-20-16	1.5/8"X12	1.5/16"X12	37.46X3.00	15.1	40	50
50-20-24	1.5/8"X12	1.7/8"X12	37.46X3.00	15.1	40	55
50-24-12	1.7/8"X12	1.1/16"X12	43.69X3.00	15.1	40	55
50-24-16	1.7/8"X12	1.5/16"X12	43.69X3.00	15.1	40	55
50-24-20	1.7/8"X12	1.5/8"X12	43.69X3.00	15.1	40	55
50-32-16	2.1/2"X12	1.5/16"X12	59.36X3.00	15.1	40	70
50-32-20	2.1/2"X12	1.5/8"X12	59.36X3.00	15.1	40	70
50-32-24	2.1/2"X12	1.7/8"X12	59.36X3.00	15.1	40	70

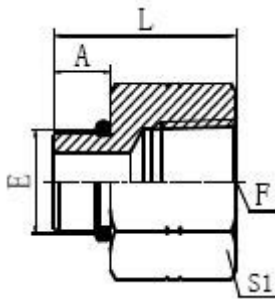

50N

美制 SAE 外螺纹带 O 形圈/布锥管内螺纹

SAE O-RING BOSS/NPT FEMALE

代号 P/N	螺纹 Thread		O RING	尺寸 DIMENSIONS		
	E	F	E END	A	L	S1
50N-04-02	7/16"X20	Z1/8"X27	8.92X1.83	9.1	26	17
50N-04	7/16"X20	Z1/4"x18	8.92X1.83	9.1	30.5	19
50N-04-06	7/16"X20	Z3/8"x18	8.92X1.83	9.1	30.7	24
50N-05-02	1/2"X20	Z1/8"X27	10.52X1.83	9.1	26	17
50N-06-04	9/16"X18	Z1/4"x18	11.89X1.98	9.9	31.5	19
50N-08-04	3/4"X16	Z1/4"x18	16.36X2.21	11.1	32.5	22
50N-08-06	3/4"X16	Z3/8"x18	16.36X2.21	11.1	34	22
50N-08	3/4"X16	Z1/2"X14	16.36X2.21	11.1	40	30
50N-08-12	3/4"X16	Z3/4"x14	16.36X2.21	11.1	40.1	36
50N-10-04	7/8"X14	Z1/4"x18	19.18X2.46	12.7	34	27
50N-10-08	7/8"X14	Z1/2"x14	19.18X2.46	12.7	41.5	30
50N-10-06	7/8"X14	Z3/8"x18	19.18X2.46	12.7	35.5	27
50N-10-12	7/8"X14	Z3/4"x14	19.18X2.46	12.7	41	36
50N-12-08	1.1/16"X12	Z1/2"x14	23.47X2.95	15.1	42	32
50N-12	1.1/16"X12	Z3/4"x14	23.47X2.95	15.1	45.5	36
50N-12-16	1.1/16"X12	Z1"X11.5	23.47X2.95	15.1	50.3	41
50N-14-08	1.3/16"X12	Z1/2"x14	26.62X2.95	15.1	40	36
50N-14-12	1.3/16"X12	Z3/4"x14	26.62X2.95	15.1	43	36

5ON-16-08	1.5/16"X12	Z1/2"x14	29.74X2.95	15.1	42	38
5ON-16-12	1.5/16"X12	Z3/4"x14	29.74X2.95	15.1	43	38
5ON-16	1.5/16"X12	Z1"X11.5	29.74X2.95	15.1	51.5	41
5ON-20-16	1.5/8"X12	Z1"X11.5	37.46X3.00	15.1	42	50
5ON-20	1.5/8"X12	Z1.1/4"X11.5	37.46X3.00	15.1	53.5	50
5ON-24-16	1.7/8"X12	Z1"X11.5	43.69X3.00	15.1	45	55
5ON-24	1.7/8"X12	Z1.1/2"X11.5	43.69X3.00	15.1	53.5	60
5ON-32-16	2.1/2"X12	Z1"X11.5	59.36X3.00	15.1	45	70
5ON-32-24	2.1/2"X12	Z1.1/2"X11.5	59.36X3.00	15.1	45	70
5ON-32	2.1/2"X12	2"X11.5	59.36X3.00	15.1	53.5	70

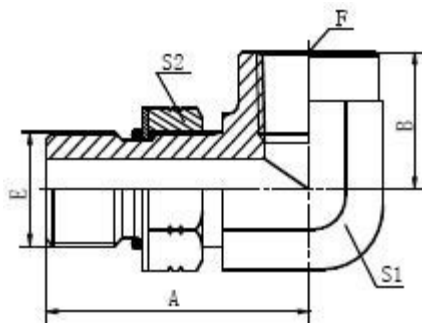

5ON9-OG

90° SAE 外螺纹带 O 形圈/布锥管内螺纹

90° SAE O-RING BOSS/NPT FEMALE

代号 P/N	螺纹 Thread		O RING	尺寸 DIMENSIONS			
	E	F	E END	A	B	S1	S2
5ON9-04OG	7/16"X20	Z1/4"X18	8.92X1.83	31.5	22.4	16	17
5ON9-04-02OG	7/16"X20	Z1/8"X27	8.92X1.83	30	16.8	14	17
5ON9-05-02OG	1/2"X20	Z1/8"X27	10.52X1.83	30	16.8	14	17
5ON9-05-04OG	1/2"X20	Z1/4"X18	10.52X1.83	31.5	22.4	16	17
5ON9-06OG	9/16"X18	Z3/8"X18	11.89X1.98	36.5	26.5	22	19

5ON9-06-04OG	9/16"X18	Z1/4"X18	11.89X1.98	33.3	22.4	16	17
5ON9-06-08OG	9/16"X18	Z1/2"X14	11.89X1.98	40	31.2	27	19
5ON9-08OG	3/4"X16	Z1/2"X14	16.36X2.21	43	31.2	27	24
5ON9-08-06OG	3/4"X16	Z3/8"X18	16.36X2.21	40	26.5	22	24
5ON9-08-12OG	3/4"X16	Z3/4"X14	16.36X2.21	47	34.5	33	24
5ON9-10-06OG	7/8"X14	Z3/8"X18	19.18X2.46	44	26.5	22	27
5ON9-10-08OG	7/8"X14	Z1/2"X14	19.18X2.46	48	31.2	27	27
5ON9-12OG	1.1/16"X12	Z3/4"X14	23.47X2.95	55	34.5	33	32
5ON9-12-08OG	1.1/16"X12	Z1/2"X14	23.47X2.95	51	31.2	27	32
5ON9-12-16OG	1.1/16"X12	Z1"X11.5	23.47X2.95	59.5	41.1	41	32
5ON9-14-12OG	1.3/16"X12	Z3/4"X14	26.62X2.95	56	34.5	33	36
5ON9-16OG	1.5/16"X12	Z1"X11.5	26.62X2.95	59.5	41.1	41	41
5ON9-16-12OG	1.5/16"X12	Z3/4"X14	29.74X2.95	54.5	34.5	33	41
5ON9-20OG	1.5/8"X12	Z1.1/4"X11.5	37.46X3.00	63	43.2	48	50
5ON9-24OG	1.7/8"X12	Z1.1/2"X11.5	43.69X3.00	76	52.8	63	55

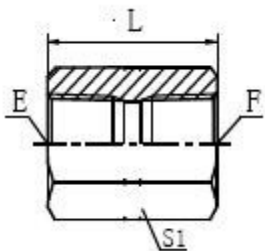

纹

7N 布锥管内螺

NPT FEMALE

代号 P/N	螺纹 Thread		O RING	尺寸 DIMENSIONS			
	E	F	E END	L	S1		
7N-02	Z1/8"X27	Z1/8"X27		24	17		
7N-02-04	Z1/8"X27	Z1/4"X18		27	19		
7N-02-06	Z1/8"X27	Z3/8"X18		30	22		
7N-04	Z1/4"X18	Z1/4"X18		29	19		
7N-04-06	Z1/4"X18	Z3/8"X18		31	22		
7N-04-08	Z1/4"X18	Z1/2"X14		35	30		
7N-04-12	Z1/4"X18	Z3/4"X14		39.5	36		
7N-06	Z3/8"X18	Z3/8"X18		29	22		
7N-06-08	Z3/8"X18	Z1/2"X14		38	30		
7N-06-12	Z3/8"X18	Z3/4"X14		40	36		
7N-08	Z1/2"X14	Z1/2"X14		38	30		
7N-08-12	Z1/2"X14	Z3/4"X14		43	36		
7N-12	Z3/4"X14	Z3/4"X14		39	36		
7N-12-16	Z3/4"X14	Z1"X11.5		45.5	41		
7N-16	Z1"X11.5	Z1"X11.5		48	41		
7N-20	Z1.1/4"X11.5	Z1.1/4"X11.5		49	50		
7N-24	Z1.1/2"X11.5	Z1.1/2"X11.5		49	60		
7N-32	Z2"X11.5	Z2"X11.5		50	70		

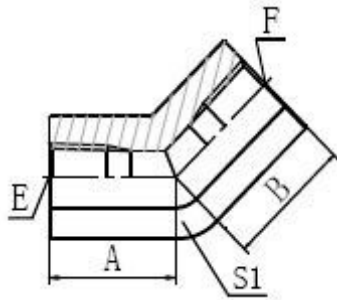

7N4

45° 布锥管内螺纹

45° NPT FEMALE

代号 P/N	螺纹 Thread		O RING	尺寸 DIMENSIONS			
	E	F	E END	A	B	S1	
7N4-02	Z1/8"X27	Z1/8"X27		18.5	18.5	16	
7N4-04	Z1/4"X18	Z1/4"X18		20	20	19	
7N4-06	Z3/8"X18	Z3/8"X18		25	25	24	
7N4-08	Z1/2"X14	Z1/2"X14		27.5	27.5	27	
7N4-12	Z3/4"X14	Z3/4"X14		31.5	31.5	33	
7N4-16	Z1"X11.5	Z1"X11.5		37.5	37.5	41	

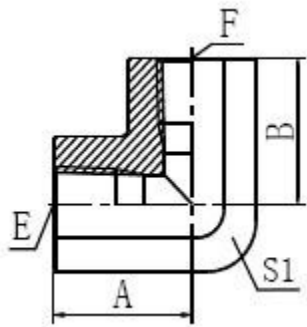

7N9

90° 布锥管内螺纹

90° NPT FEMALE

代号 P/N	螺纹 Thread		O RING	尺寸 DIMENSIONS			
	E	F	E END	A	B	S1	
7N9-02	Z1/8"X27	Z1/8"X27		20	20	16	
7N9-04	Z1/4"X18	Z1/4"X18		22.5	22.5	19	
7N9-04-06	Z1/4"X18	Z3/8"X18		25	26	24	
7N9-06	Z3/8"X18	Z3/8"X18		26	26	24	
7N9-08	Z1/2"X14	Z1/2"X14		31	31	27	
7N9-12	Z3/4"X14	Z3/4"X14		34	34	33	
7N9-16	Z1"X11.5	Z1"X11.5		42	42	41	
7N9-20	Z1.1/4"X11.5	Z1.1/4"X11.5		48	48	50	
7N9-24	Z1.1/2"X11.5	Z1.1/2"X11.5		53	53	60	
7N9-32	Z2"X11.5	Z2"X11.5		62	62	70	

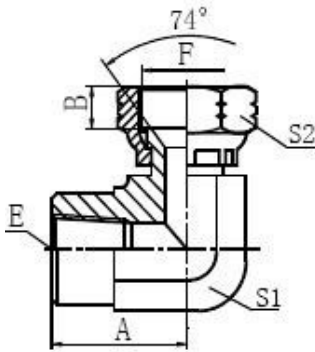

7NJ9-S

90° 美制锥管内螺纹/JIC 内螺纹 74°内锥

90° NPT FEMALE/JIC FEMALE 74°

代号 P/N	螺纹 Thread		O RING E END	尺寸 DIMENSIONS			
	E	F		A	B	S1	S2
7NJ9-04S	Z1/4"X18	7/16"X20		22.5	9	19	15
7NJ9-06S	Z3/8"X18	9/16"X18		27	10.5	24	19
7NJ9-06-08S	Z3/8"X18	3/4"X16		27	10.5	24	24
7NJ9-08S	Z1/2"X14	3/4"X16		31.2	10.5	30	24
7NJ9-08-10S	Z1/2"X14	7/8"X14		31.2	12	30	27
7NJ9-12S	Z3/4"X14	1.1/16"X12		34.5	15	33	32
7NJ9-16S	Z1"X11.5	1.5/16"X12		43	16	41	41
7NJ9-20S	Z1.1/4"X11.5	1.5/8"X12		43.2	17	50	50
7NJ9-24S	Z1.1/2"X11.5	1.7/8"X12		52.8	20	63	60

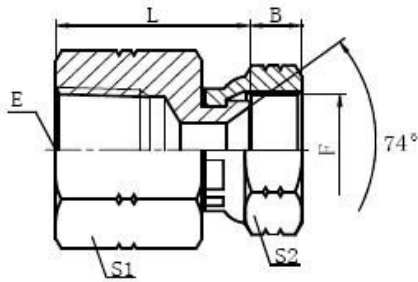

7NJ-S

布锥管内螺纹/JIC 内螺纹 74_内锥

NPT FEMALE/JIC FEMALE 74° SEAT

代号 P/N	螺纹 Thread		尺寸 DIMENSIONS				
	E	F	A	B	L	S1	S2
7NJ-04S	Z1/4"X18	7/16"X20	21	9	29	19	15
7NJ-06S	Z3/8"X18	9/16"X18	21.5	10.5	30	24	19
7NJ-06-08S	Z3/8"X18	3/4"X16	21.5	11	32	24	24
7NJ-08S	Z1/2"X14	3/4"X16	27	11	37.5	30	24
7NJ-08-10S	Z1/2"X14	7/8"X14	27	14	38	30	27
7NJ-12S	Z3/4"X14	1.1/16"X12	28	15	40.5	36	32
7NJ-16S	Z1"X11.5	1.5/16"X12	35	16	47.5	41	41

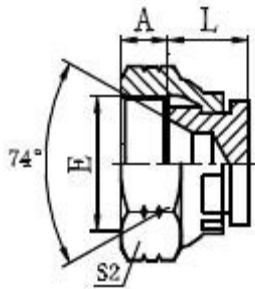

9J

美制 JIC 内螺纹 74°内锥堵头

JIC FEMALE 74° SEAT PLUG

代号 P/N	螺纹 Thread		O RING	尺寸 DIMENSIONS			
	E	F	E END	A	L	S2	
9J-04	7/16"X20			9	10.5	15	
9J-05	1/2"X20			9.5	11	17	
9J-06	9/16"X18			10.5	11	19	
9J-08	3/4"X16			11	13	24	
9J-10	7/8"X14			13	14	27	
9J-12	1.1/16"X12			15	15.5	32	
9J-14	1.3/16"X12			15	16	36	
9J-16	1.5/16"X12			16	17	41	
9J-20	1.5/8"X12			17	19	50	
9J-24	1.7/8"X12			20	21	55	
9J-32	2.1/2"X12			24.5	29	75	

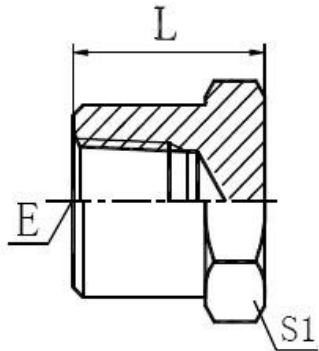

9N

美制布锥管内螺纹堵头

NPT FEMALE PLUG

代号 P/N	螺纹 Thread		O RING	尺寸 DIMENSIONS			
	E	F	E END	L	S1		
9N-02	Z1/8"X27			17.5	17		
9N-04	Z1/4"X18			23	19		
9N-06	Z3/8"X18			24	24		
9N-08	Z1/2"X14			28	30		
9N-12	Z3/4"X14			28	36		
9N-16	Z1"X11.5			34	46		
9N-20	Z1.1/4"X11.5			37	55		
9N-24	Z1.1/2"X11.5			37	65		
9N-32	Z2"X11.5			40.5	75		

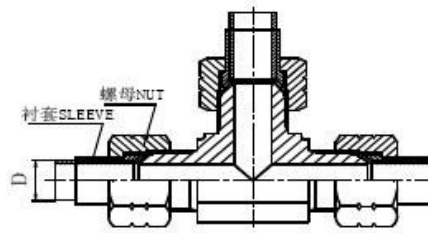
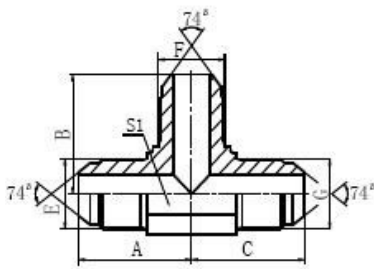

AJ 美制 JIC 外螺纹

74°外锥

JIC MALE 74° CONE

代号 P/N	螺纹 Thread			尺寸 DIMENSIONS			
	E	F	G	A	B	C	S1
AJ-04	7/16"X20	7/16"X20	7/16"X20	24.5	24.5	24.5	11
AJ-04-06-04	7/16"X20	9/16"X18	7/16"X20	26.6	26.9	26.6	14
AJ-05	1/2"X20	1/2"X20	1/2"X20	26	26	26	14
AJ-06-04-06	9/16"X18	7/16"X20	9/16"X18	26.9	26.6	26.9	14
AJ-06	9/16"X18	9/16"X18	9/16"X18	26.9	26.9	26.9	14
AJ-08	3/4"X16	3/4"X16	3/4"X16	32	32	32	19
AJ-08-06-08	3/4"X16	9/16"X18	3/4"X16	32	30	32	19
AJ-10	7/8"X14	7/8"X14	7/8"X14	37.8	37.8	37.8	22
AJ-10-12-10	7/8"X14	1.1/16"X12	7/8"X14	41	44.2	41	27
AJ-12	1.1/16"X12	1.1/16"X12	1.1/16"X12	44.2	44.2	44.2	27
AJ-12-08-12	1.1/16"X12	3/4"X16	1.1/16"X12	44.2	37.9	44.2	27

AJ-16	1.5/16"X12	1.5/16"X12	1.5/16"X12	49	49	49	33
AJ-20	1.5/8"X12	1.5/8"X12	1.5/8"X12	56.5	56.5	56.5	41
AJ-24	1.7/8"X12	1.7/8"X12	1.7/8"X12	63	63	63	48

Note: Nut and sleeve should be ordered separately. The nut NB200 and sleeve NB500 is suitable for metric tube, the nut NB200 and sleeve NB300 is suitable for inch tube.

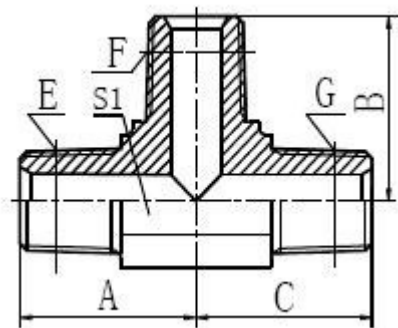

AN

美制布锥管外螺纹

NPT MALE

代号 P/N	螺纹 Thread			尺寸 DIMENSIONS			
	E	F	G	A	B	C	S1
AN-02	Z1/8"X27	Z1/8"X27	Z1/8"X27	21	21	21	11
AN-04	Z1/4"X18	Z1/4"X18	Z1/4"X18	25.5	25.5	25.5	14
AN-06	Z3/8"X18	Z3/8"X18	Z3/8"X18	31	31	31	19
AN-08	Z1/2"X14	Z1/2"X14	Z1/2"X14	36.7	36.7	36.7	22
AN-12	Z3/4"X14	Z3/4"X14	Z3/4"X14	44	44	44	27
AN-16	Z1"X11.5	Z1"X11.5	Z1"X11.5	50	50	50	33
AN-20	Z1.1/4"X11.5	Z1.1/4"X11.5	Z1.1/4"X11.5	54.5	54.5	54.5	41
AN-24	Z1.1/2"X11.5	Z1.1/2"X11.5	Z1.1/2"X11.5	63	63	63	48

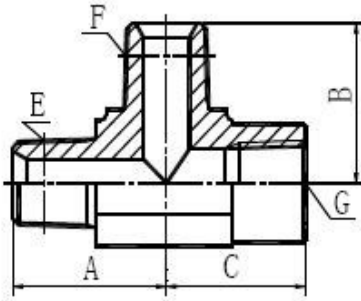

JN

布锥管内螺纹/布锥管外螺纹/布锥管内螺纹

NPT FEMALE/NPT MALE/NPT FEMALE

代号 P/N	螺纹 Thread			尺寸 DIMENSIONS			
	E	F	G	A	B	C	S1
JN-02	Z1/8"X27	Z1/8"X27	Z1/8"X27	17.8	23.5	17.8	14
JN-04	Z1/4"X18	Z1/4"X18	Z1/4"X18	22.4	28	22.4	19
JN-06	Z3/8"X18	Z3/8"X18	Z3/8"X18	25	33.5	25	24
JN-08	Z1/2"X14	Z1/2"X14	Z1/2"X14	31.2	41.2	31.2	30
JN-12	Z3/4"X14	Z3/4"X14	Z3/4"X14	34.5	45.2	34.5	33
JN-16	Z1"X11.5	Z1"X11.5	Z1"X11.5	41.1	54.5	41.1	41

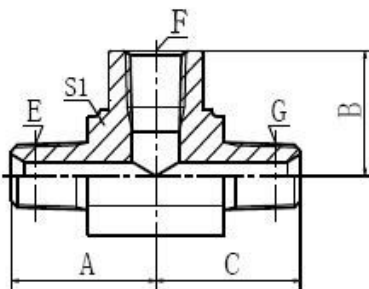

KN 布锥管外螺纹/布锥管内螺纹/布锥管外螺纹

NPT MALE/NPT FEMALE/NPT MALE

代号 P/N	螺纹 Thread			尺寸 DIMENSIONS			
	E	F	G	A	B	C	S1
KN-02	Z1/8"X27	Z1/8"X27	Z1/8"X27	24.5	17.8	24.5	16

KN-04	Z1/4"X18	Z1/4"X18	Z1/4"X18	28	22.4	28	19
KN-06	Z3/8"X18	Z3/8"X18	Z3/8"X18	33.5	25	33.5	24
KN-08	Z1/2"X14	Z1/2"X14	Z1/2"X14	41.2	31.2	41.2	30
KN-12	Z3/4"X14	Z3/4"X14	Z3/4"X14	45.2	34.5	45.2	33
KN-16	Z1"X11.5	Z1"X11.5	Z1"X11.5	54.5	41.1	54.5	41

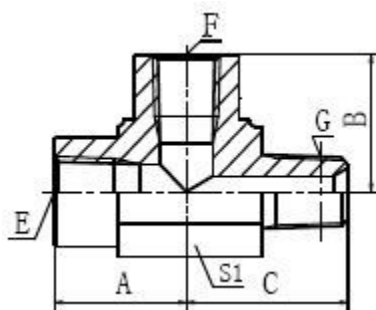

HN

布锥管内螺纹/布锥管内螺纹/布锥管外螺纹

NPT FEMALE/NPT FEMALE/NPT MALE

代号 P/N	螺纹 Thread			尺寸 DIMENSIONS			
	E	F	G	A	B	C	S1
HN-02	Z1/8"X27	Z1/8"X27	Z1/8"X27	20	20	24.5	16
HN-04	Z1/4"X18	Z1/4"X18	Z1/4"X18	25	25	28.5	19
HN-06	Z3/8"X18	Z3/8"X18	Z3/8"X18	27	27	33.5	24
HN-08	Z1/2"X14	Z1/2"X14	Z1/2"X14	35	35	42.5	30
HN-12	Z3/4"X14	Z3/4"X14	Z3/4"X14	37	37	45.2	33
HN-16	Z1"X11.5	Z1"X11.5	Z1"X11.5	44	44	54.7	41
HN-20	Z1.1/4"X11.5	Z1.1/4"X11.5	Z1.1/4"X11.5	48	48	58.5	48

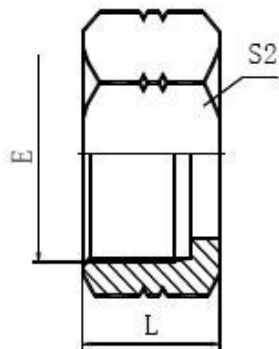

NB200

JIC 螺母

JIC TRIPLE LOCK NUT

代号 P/N	螺纹 Thread		管子外径 TUBE O. D		尺寸 DIMENSIONS		
	E	F	In	Mm	L	S1	
NB200-04	7/16"X20		1/4"	6	15.8	14	
NB200-05	1/2"X20		5/16"	8	17.3	17	
NB200-06	9/16"X18		3/8"	10	18.5	19	
NB200-08	3/4"X16		1/2"	12	21.6	24	
NB200-10	7/8"X14			14	24.9	27	
NB200-10	7/8"X14			15	24.9	27	
NB200-10	7/8"X14		5/8"	16	24.9	27	
NB200-12A	1.1/16"X12			20	26.2	32	
NB200-12	1.1/16"X12		3/4"	18	26.2	32	
NB200-14	1.3/16"X12		7/8"	22	27.7	36	
NB200-16	1.5/16"X12		1"	25	28.7	38	
NB200-20	1.5/8"X12			28	31.2	50	
NB200-20	1.5/8"X12			30	31.2	50	
NB200-20	1.5/8"X12		1.1/4"	32	31.2	50	
NB200-24	1.7/8"X12			35	36.1	60	

NB200-24	1.7/8"X12		1.1/2"	38	36.1	60	
NB200-24/5J	1.7/8"X12			38	36.1	60	
NB200-32	2.1/2" X12		2"	50	44.5	75	
Note: NB200-2A for use with NB500-20A ONLY							

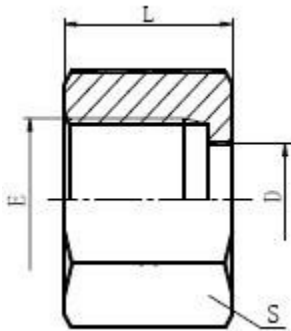

NB200-F

ORFS 螺母

ORFS NUT

代号 PART NO.	螺 纹	管子外径及配用管套				尺 寸		
	THREAD	TUBE O.D.& SLEEVE				DIMENSIONS		
	THREAD E	In.	INCH SLEEVE	mm	METRIC SLEEVE	L	S	D
NB200-04F	9/16"X18	0.250	NB300-04F	6	NB500-06F	14.7	19	10.5
NB200-06F	11/16"X16	0.375	NB300-06F	10	NB500-10F	17	22	13.5
NB200-08F	13/16"X16	0.500	NB300-08F	12	NB500-12F	21	27	16.5
NB200-10F	1"X14	0.625	NB300-10F	16	NB500-16F	23.5	30	21
NB200-12F	1.3/16"X12	0.750	NB300-12F	19	NB500-19F	26	36	24.1
NB200-16F	1.7/16"X12	1.000	NB300-16F	25	NB500-25F	27.8	41	29
NB200-20F	1.11/16"X12	1.250	NB300-20F	32	NB500-32F	27.8	50	36
NB200-24F	2"X12	1.500	NB300-24F	38	NB500-38F	27.8	60	44

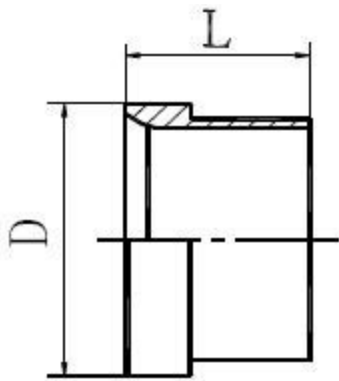

NB300

JIC 英制管套

JIC INCH SLEEVE

代号 P/N	螺纹 hread	管子外径 TUBE O. D		尺寸 DIMENSIONS		
		In	Mm	D	L	
NB300-04	7/16"X20	1/4"		9.73	10.4	
NB300-05	1/2"X20	5/16"		11.3	11.2	
NB300-06	9/16"X18	3/8"		12.75	12.7	
NB300-08	3/4"X16	1/2"		17.32	14.2	
NB300-10	7/8"X14	5/8"		20.24	16.8	
NB300-12	1.1/16"X12	3/4"		24.69	17.3	
NB300-14	1.3/16"X12	7/8"		27.86	19.3	
NB300-16	1.5/16"X12	1"		31.04	19.8	
NB300-20	1.5/8"X12	1.1/4"		38.96	23.1	
NB300-24	1.7/8"X12	1.1/2"		45.31	28.4	
NB300-32	2.1/2"X12	2"		61.19	30.2	

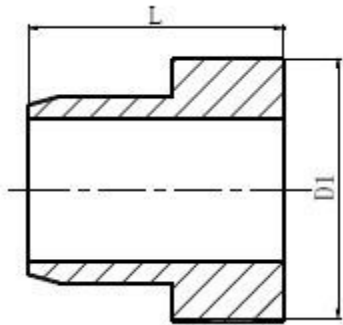

NB300-F

ORFS 英制支撑环

ORFS INCH SLEEVE

代号 P/N	螺纹 Thread		管子外径 TUBE O. D		尺寸 DIMENSIONS		
			In.	Mm	D1	L	
NB300-04F	9/16"X18		0.250		12.8	8.5	
NB300-06F	11/16"X16		0.375		15.8	8.5	
NB300-08F	13/16"X16		0.500		18.9	8.5	
NB300-10F	1"X14		0.625		23.4	9	
NB300-12F	1.3/16"X12		0.750		27.9	12.5	
NB300-16F	1.7/16"X12		1.000		34.2	14	
NB300-20F	1.11/16"X12		1.250		40.6	14	
NB300-24F	2"X12		1.500		48.5	14	

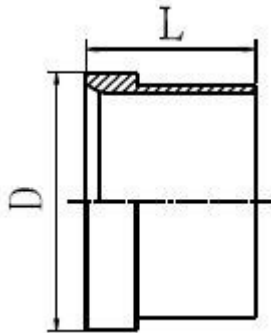

NB500

JIC 公制管套

JIC METRIC SLEEVE

代号 P/N	螺纹 thread		管子外径 TUBE O. D		尺寸 DIMENSIONS		
			In	mm	D	L	
NB500-06	7/16"	X20		6	9.7	10.4	
NB500-08	1/2"	X20		8	11.3	11.2	
NB500-10	9/16"	X18		10	12.7	12.7	
NB500-12	3/4"	X16		12	17.3	14.2	
NB500-14	7/8"	X14		14	20.2	16.8	
NB500-15	7/8"	X14		15	20.2	16.8	
NB500-16	7/8"	X14		16	20.2	16.8	
NB500-18	1.1/16"	X12		18	24.7	17.3	
NB500-20	1.3/16"	X12		20	27.8	19.3	
NB500-22	1.3/16"	X12		22	27.8	19.3	
NB500-25	1.5/16"	X12		25	31	19.8	
NB500-28	1.5/8"	X12		28	38.9	23.1	

NB500-30	1.5/8"X12			30	38.9	23.1	
NB500-32	1.5/8"X12			32	38.9	23.1	
NB500-35	1.7/8"X12			35	45.3	28.4	
NB500-38	1.7/8"X12			38	45.3	28.4	
NB500-50	2.1/2"X12			50	61.2	30.2	

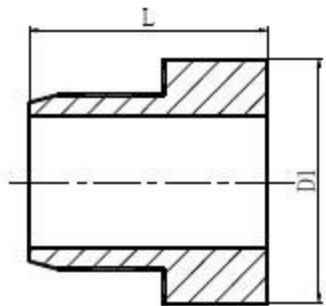

NB500-F

ORFS 公制支撑环

ORFS METRIC SLEEVE

代号 P/N	螺纹 Thread		管子外径 TUBE O. D		尺寸 DIMENSIONS		
			In	MM	D1	L	
NB500-06F	9/16"X18			6	12.8	8.5	
NB500-10F	11/16"X16			10	15.8	8.5	
NB500-12F	13/16"X16			12	18.9	8.5	
NB500-16F	1"X14			16	23.4	9	
NB500-19F	1.3/16"X12			19	27.9	12.5	
NB500-25F	1.7/16"X12			25	34.2	14	
NB500-32F	1.11/16"X12			32	40.6	14	
NB500-38F	2"X12			38	48.5	14	

NOTES

The drawings in this catalogue are for reference only, and their dimensions and proportions may be a little different from those of the real products.

Products included in this catalogue don't refer to all, so if customers are interested in other products, please don't hesitate to contact our company for further information.

Our company has made much effort to record the correct data in this publication. However, in order to promote our products, we may make some changes of their size or description, which haven't been shown yet. We reserve the rights for explanation, but sorry for no further notice to customer the change of products' design, description or even stop of some products' manufacture in future.